

McHale 991 High speed



991 High Speed Round Bale Wrapper Operator Instruction Manual Issue 5

McHale
Ballinrobe
Co. Mayo,
F31 K138 Ireland

Tel: +353 94 9520300
Email: sales@mchale.net
Website: www.mchale.net





ENVIRONMENT: Reduce paper consumption

Think before printing documents! Is a PDF on a laptop or tablet sufficient? If a printed copy is required, always select 'Print on both sides of paper' and always try to limit the number of printed pages by selecting a specific page range or just select 'Current page' if that is sufficient.

This is the original operator manual with 'Original Instructions'. The English language version of the operator manual is the source document for all translations.

If there is any conflict as to the accuracy or content, of any translation, the English source manual remains the authorised document.

No part of this manual may be reproduced, distributed or translated, in any form or by any means, without prior written permission by **McHale**.

McHale 991 High Speed Round Bale Wrapper

Thank you for buying this **McHale** machine, you have chosen wisely!
Given proper care and attention, you can expect it to provide you with
years of dependable service.

Warranty/Guarantee

Attention End User!

Please ensure your machine is fully registered with **McHale**,
by your dealer, at the time of delivery.
Failure of the dealer to register the machine will render your warranty void!
You can check the registration of your machine by visiting **www.mchale.net**.

It is important to quote the machine serial number when ordering spare parts or
requesting technical assistance. Space is provided below to record machine details.

Serial number:	
Year of manufacture:	
Date of delivery:	

If you require further copies of this instruction manual,
please quote part number: CLT00218

Due to a policy of continuous product development and improvement, **McHale**
Engineering reserves the right to alter machine specifications, including the contents of
this manual, without prior notice or any obligation to make changes or additions to the
equipment previously sold. Images and screenshots used in this manual may differ in
appearance from the actual product.

It is vital to replace defective parts of the machine immediately and to use only genuine
McHale spare parts, as these are designed and manufactured to the same standard
as the original machine. Spare parts can be obtained from your **McHale** dealer.

Throughout this manual there are links to other relevant sections of the manual, to
guide the reader to additional information to convey the complete message. These
links are in *(grey italic font)*. See the example above i.e. the link to the description of
the serial number plate. When you click on the link in the PDF document, the page will
jump automatically to the linked section. With Adobe Reader, you can go back to the
page on which you clicked the link, by clicking on the 'Previous view' button (or by
holding 'Alt' and pressing the 'left arrow').

Table of contents

1	Introduction	6
2	Product information	7
2.1	Designated use of the machine	7
2.2	Front view	8
2.3	General specifications	9
2.4	Tractor specifications	9
2.5	Machine specifications	9
2.6	Tyre specifications	10
2.7	Optional equipment*	10
3	General safety	11
3.1	Be aware of all safety information	11
3.2	Follow all safety instructions	11
3.3	Store all items carefully	12
3.4	Protective clothing	12
3.5	In case of emergencies	12
3.6	Stay clear of moving parts	12
3.7	Trained operator criteria	13
3.8	In the event of a fire	13
3.9	General safety warnings	14
4	Specific safety warnings	19
4.1	Electronic safety warnings	19
4.2	Hydraulic safety warnings	19
4.3	Noise level	20
4.4	Fire precautions	20
4.5	Safety instruction decal locations	21
4.6	Safety warnings & instructions explained	22
4.7	Machine lifting guidelines	27
4.8	Jacking guidelines	28
5	Tractor requirements & preparation	29
5.1	Tractor requirements	29
5.2	Hydraulic spool valve setup	30
5.3	Attaching the wrapper	31
5.4	Connecting the control box	32
6	Bale & plastic film requirements	33
6.1	Bale requirements	33
6.2	Plastic film requirements	33
6.3	Care of the film roll	34

McHale 991 High Speed Round Bale Wrapper

7	Electronic control system	36
7.1	Electronic control box	36
7.2	Electronic control box functions	37
7.3	Available wrapping programs	38
7.4	Electronic control box setup	39
7.5	Electronic control box features	40
7.6	Counters	41
8	Wrapper operation	50
8.1	Preparing the machine for wrapping	50
8.2	Loading plastic film	51
8.3	Dispenser gears	54
8.4	Side-tip bale damper	55
8.5	Wrapping behind the tractor	55
9	Road traffic safety & operation	57
9.1	Before travelling on any public roadway	57
10	Field operation & wrapper adjustments	58
10.1	Drawbar height	58
10.2	Dispenser height	59
10.3	Table rollers/belts	59
10.4	Adjusting table magnets	60
10.5	Bale damper lift height	63
10.6	Bale damper drop speed	63
10.7	Table drive roller shearbolt replacement	64
10.8	Gearbox cross shaft roll pin replacement	64
10.9	Cut & hold accumulator pressure	65
10.10	Chain adjustments	66
11	Machine maintenance	68
11.1	Maintenance intervals	68
11.2	Tightening torque values	73
12	Storage	74
12.1	End of season	74
12.2	Start of season	74
13	Troubleshooting	75
13.1	Troubleshooting overview	75
14	Certification & Warranty	79
14.1	Declaration of Conformity	79
14.2	PDI form	79
14.3	Change of ownership pre-checks	79
14.4	Limited Warranty	79

1

Introduction

This product is designed to wrap, with plastic stretch film, cylindrical section bales of forage for the purpose of storage as fodder for livestock. The design has been developed based on years of extensive research and development in the field of round bale wrappers. Given proper care and attention, the machine will provide years of reliable and dependable performance.

Please do not assume that you know how to operate and maintain your machine before reading this manual carefully. In order to prevent misuse, damage and accidents, it is very important that everybody who will operate the machine is a fully trained machine operator. (See *'Trained operator criteria'*). They must read and fully understand all of the contents of this manual, before operating the machine, paying particular attention to the following:

- Safety instructions
- Functions
- Controls (hydraulic & electrical)

It is highly recommended to get acquainted with any new machinery slowly. Take time to learn and understand all of the features of the machine. Proficiency will increase as more experience is obtained.

If you have any questions in relation to the instructions in the manual, please contact your **McHale** dealer. It is highly recommended that training be sought from your local **McHale** dealer.

The operator is solely responsible for the safe use and maintenance of the machinery, in accordance with this manual. Keep this manual safe and make sure it remains with the machine, at all times.



ENVIRONMENT: Reduce paper consumption

Think before printing documents! Is a PDF on a laptop or tablet sufficient? If a printed copy is required, always select 'Print on both sides of paper' and always try to limit the number of printed pages by selecting a specific page range or just select 'Current page' if that is sufficient.

2

Product information

The machine is protected against many dangers to itself while being operated from the control box, in manual and fully automatic modes. However, it is of the utmost importance for the safety of the operator and for others, that the operator pays attention to all warnings and instructions given in this manual. In particular all safety devices, decals, guards and controls must be in place and in fully functioning condition. Never try to clear any malfunction when the tractor is switched on or while the machine is running. Keep the 'Danger Zone' (an area around the machine) free of all persons and animals at all times, while the machine is in operation (See 'Danger Zone'). This manual must be read and fully understood by anyone who will operate the machine.

2.1 Designated use of the machine

The machine is exclusively designed for normal use in agricultural applications. The machine has been designed to wrap cylindrical bales of forage with plastic stretch film for the purpose of storing as fodder for feeding livestock. This designation includes the movement of the machine, between fields by track or road, incidental to the machine's main use. The manufacturer will not be held responsible for any loss or damage resulting from machine applications other than those specified above. Any other use the machine may be put to is entirely at the owner/operator's risk.

The designated use of the machine includes that:

- The operating, maintenance and repair instructions given by the manufacturer will be strictly fulfilled
- Exclusively persons who are familiar with it and instructed about the risks are entitled to operate, maintain and/or repair the machine
- The relevant health and safety requirements, that may be in force in the country of use, will be strictly followed
- No other equipment or accessories, other than released by **McHale**, are installed in the machine. The use of any other equipment or accessory is entirely at the owner/operator's risk. In such cases, unauthorised modifications/changes exclude any liability of the manufacturer.



WARNING: Loss of machine validity

By any alteration of safety equipment, the declaration of conformity and the CE sign loses its validity for this machine.

2.2 Front view

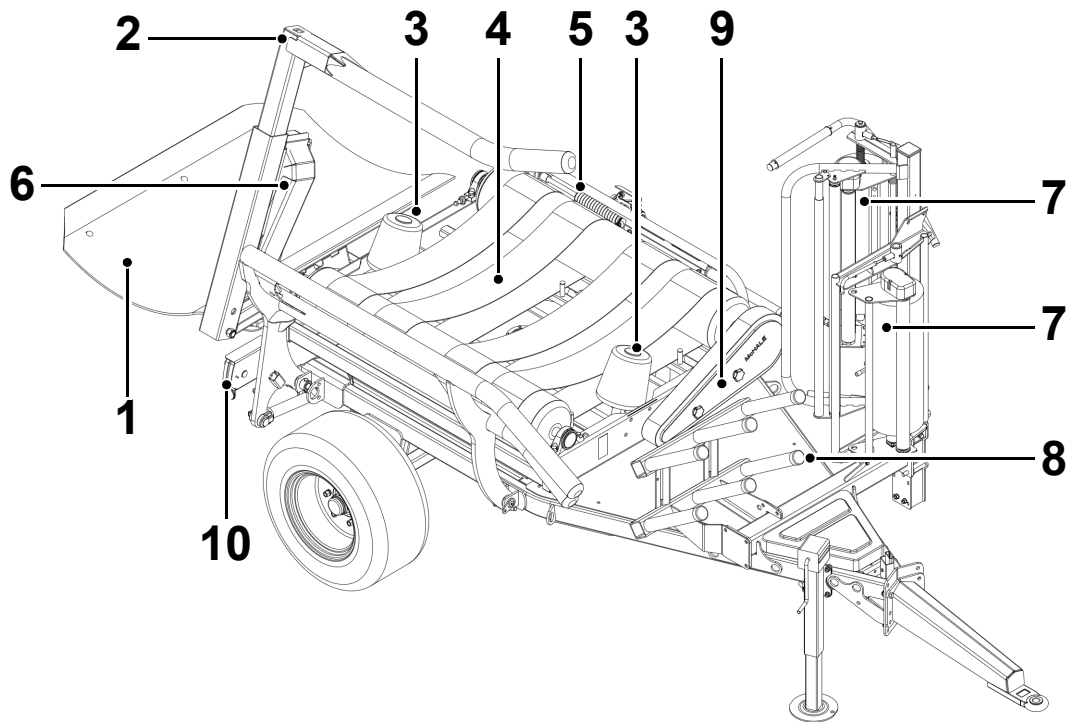

No.	Machine function
1	Side-tip damper
2	Lift arm
3	Bale support bobbin
4	Rotating table
5	Cut and hold
6	Bale detect sensor
7	2 x quick fit dispensers
8	Spare film roll holders
9	Shearbolt unit
10	Road lights

2.3 General specifications

Units are given in both metric and UK imperial values, with the latter shown in brackets.

Transport length	5.7 m (18' 8")
Transport width	2.45 m (8' 0")
Transport height	2.46 m (8' 1")
Height to top of rollers	1.25 m (4' 1")
Transport weight (unladen)	2,125 kg (4,685 lbs)
Axle weight (unladen)	1,900 kg (4,189 lbs)
Maximum road speed*	40 km/h (25 mph)

*Check with national road traffic regulations in the individual country!

2.4 Tractor specifications

Attachment	Pin hitch
Towing tractor requirements	35 kW (47 hp)
Electrics	12 V DC, 7 A approx.
Hydraulic systems	Open-centre, closed-centre, load-sensing
Minimum hydraulic pressure	170 bar (2,465 psi)
Minimum hydraulic flow rate	22 l/min (4.8 gal/min)
Maximum rotary table speed	30 rpm

2.5 Machine specifications

Film stretch	70% (64% or 55% optional)
Film layers	2+2 system
Film width	750 mm
Maximum bale size	1.5 m (4' 9")
Maximum bale weight	1,000 kg (2,205 lbs)

2.6 Tyre specifications

Details	Type	Field pressure	Road pressure	Part No.
340/55-16 133 A8 (Vredestein)	Flo +	3.4 bar	3.2 bar	CWH00022

2.7 Optional equipment*

Side-tip	Side-tip damper
Dispenser gears	55% and 64% film stretch
Radio remote	Allows remote control of the machine
Wired remote	Remote hand piece

*May not be available in all countries, check with your **McHale** dealer for availability in your country.

Side-tip option

The side-tip option is used for knocking the bale onto its side and is very useful for coarse ground with strong stubble (which may have a tendency to puncture the film), as it allows the bale to land on its edge, which has a much higher degree of film coverage. It is also very useful on hilly/sloping ground as it can prevent bales from rolling, when they land on their side.

3

General safety

3.1 Be aware of all safety information

Follow all safety precautions and practice safe operation of machinery, at all times.

Warning, caution, note & environment messages:

When reading this manual, pay particular attention when you see the symbols below i.e. warning, caution, note and environment. They will be used at various points in this manual and may also appear on safety decals on the machine. The purpose of these messages is to ensure that the most important information stands out from the rest of the text.



WARNING: This symbol indicates a potentially hazardous situation, that if not avoided could result in machinery damage, personal injury or even death.



CAUTION: This symbol indicates a potentially hazardous situation, that if not avoided could result in machinery damage or personal injury.



NOTE: This symbol is used to identify special instructions or procedures which, if not followed strictly, could result in machinery damage.



ENVIRONMENT: This symbol reminds you to respect the environment in relation to the correct disposal of waste material.

3.2 Follow all safety instructions



Using this manual, read all safety instructions and messages, and be aware of the meanings of all safety decals. (See '*Safety warnings & instructions explained*'). The spare part codes for each decal are also listed, which are available from your **McHale** dealer. If safety decals are damaged or missing due to wear and tear or component replacement, ensure that they are replaced. As with all machinery, learn all operations and use controls by reading this manual thoroughly. Do not attempt to let anyone operate this machine without being fully instructed.

3.3 Store all items carefully



Store all attachments in a secure and safe manner so as to prevent items from falling. Keep storage areas clear of bystanders and children.

3.4 Personal protective equipment (PPE)



The following PPE should be worn, at all times, when carrying out maintenance work on this machine, to help prevent health and safety hazards:

- Safety glasses
- Ear muffs
- Safety boots
- Gloves
- Tight fitting clothing

Use of mobile phones or radio/music headphones are strictly forbidden while operating machinery and driving, as these impair the operator's attention.

3.5 In case of emergencies



In the event of any accident, emergency equipment should be kept close at hand. A first aid kit and fire extinguisher along with emergency phone numbers should always be available to machine operators.

3.6 Stay clear of moving parts

Serious injury or death can result from entanglement of clothing or body parts with PTO shafts, drivelines and other rotating and moving components.

Keep all guards in place at all times, only wear close fitting clothing and ensure that tractor engine has stopped and key is removed before carrying out any adjustments, connections or cleaning of equipment.

3.7 Trained operator criteria

Age related requirements		General requirements
18 +	The operator needs to be fully trained in the use of this machine and have a valid tractor driver's licence.	<ul style="list-style-type: none"> ■ The operator must be in full control of his/her senses and must not be under the influence of any alcohol or drugs, prescribed or otherwise. ■ The operator must have read and understood all aspects of the operator manual in order to operate, maintain and clean the machine. Ideally, they should also receive training from their McHale Dealer. ■ It is only acceptable to have more than one person in the tractor cab, if it has a second seat.
16 - 18	An operator between the age of 16 and 18 years old must have a provisional licence and must be accompanied by an experienced driver/operator, at all times, even during maintenance and cleaning!	
< 16	Persons younger than 16 years of age are not allowed to operate, clean or carry out maintenance on this machine, under any circumstances!	

3.8 In the event of a fire



In the event of a fire, it is the operator's decision to determine the seriousness and hence the solution to the situation. The following is given only as a guideline procedure:

1. Immediately tip the bale off the table and move the tractor and wrapper away from the flammable material.
2. Shutdown the tractor and remove the key from the ignition.
3. Remove all hydraulic hosing and electrical looms from the machine.
4. With all connections removed, disengage the wrapper from the tractor.
5. Drive the tractor away from the wrapper.
6. Using a suitable fire extinguisher, attempt to put out the fire.



WARNING: Fire prevention

It is recommended that the machine be kept reasonably clean and free of build-ups of crop, lubricants, etc. This will help to reduce the risk of fires.

3.9 General safety warnings

It is important to be aware of the potential hazards associated with the operation of farm machinery. Numerous research studies have shown that the majority of machinery-related accidents occur as the result of human negligence, including taking shortcuts to save time, lack of or improper maintenance, ignoring warnings, failing to read the operator's manual, lack of or improper instruction and failure to follow safety rules.

Read and understand this operator manual before using the machine. If any of the instructions appear unclear do not hesitate to contact your **McHale** dealer.

Only competent persons who have read and fully understood this manual are qualified to operate this machine. The owner of this machine is obliged, by law, to ensure that every operator understands all of the functions, controls, working processes and safety warnings, before operating the machine. (See 'Trained operator criteria')

Safety devices

- All safety devices such as guards, protection parts and safety controls must be in place and in fully functioning condition. It is forbidden to operate this machine with defective or incomplete safety devices.

Danger Zone

- The 'Danger Zone' is the area around the rotating table (approx. 5 metres radius from the rotating centre axis), 1 metre in front of the table and a minimum of 10 metres at the back of the machine to allow for safe bale discharge.

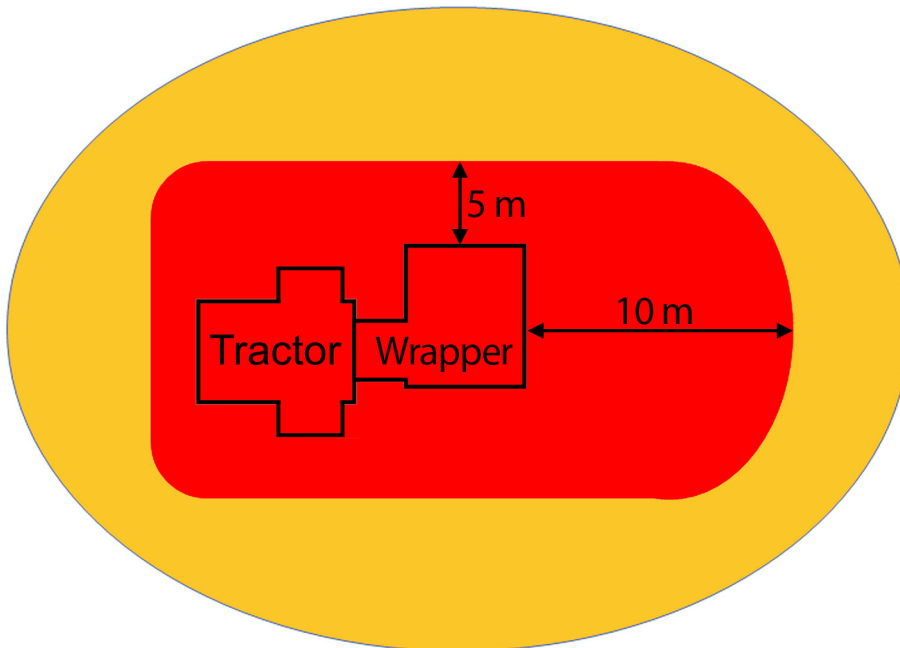

NOTE: 'Danger Zone' can vary in size

The operator must be aware of the 'Danger Zone' which can vary in size, depending on operating conditions, i.e. hilly terrain.

McHale 991 High Speed Round Bale Wrapper

- It is the operator's responsibility to ensure that there is no person in the '**Danger Zone**' while operating the machine, especially during start up.

Before repair or reassembly

- Safe lifting gear of sufficient capacity must be used for machine assembly. All chains and slings used must be in good condition.
- Extreme caution is required when fitting or adjusting the mat frame or side tip plate.

Before operation

- Never operate farm machinery while under the influence of drugs or alcohol. The physiological effects of drugs and alcohol impair performance and can lead to operators taking risks or putting others at risk. This includes over-the-counter cold/flu and allergy medications or prescription drugs that are not recommended to be taken whilst driving a car or operating machinery.
- The operator must ensure that the manufacturer's instructions for attaching and detaching the machine are followed. This includes the drawbar attachment, the electric and hydraulic lines, in particular the lighting system.
- The operator must ensure that all covers are closed and all safety devices are in operating mode.
- The operator must ensure that there is no person in the '**Danger Zone**'.
- Always be familiar with the health and safety requirements that may be in force in the country of use.

During operation

- While operating this machine on hilly or sloping ground the operator must take extra precautions, in particular the '**Danger Zone**' is increased in such conditions.
- Adjust driving speed to suit ground conditions. Allow for mounted machines reducing the front end weight of tractor.
- Precaution must be taken when travelling over sloping or rough ground due to the risk of overturning. Always travel at a speed suitable for the ground conditions.
- The operator must ensure that there is a minimum of 4 m clearance between the machine and any obstacle above, in particular electrical high voltage lines.
- Be careful when working with the cut & hold. Remember that the accumulators are under pressure.
- Avoid contact with the knife.
- Do not attempt to clamp plastic film in the cut & hold mechanism.
- Particular care must be taken, if the machine is left idle for any extended period, to ensure that all sensors and safety features are working correctly.
- The safety bar must always be used when working under a tipped table.



WARNING: Do not carry people or animals on the machine

The operator must ensure that no persons or animals are carried on the machine at any time or are hidden under the machine (on the tractor persons are only allowed to sit on the relevant seats).

Before travelling on public roads

- The owner of this machine is obliged by law to ensure that every operator has got a valid driving licence and is familiar with the road traffic regulations relating to the country of use.
- Always ensure that the electronic control box and oil supply are switched off.
- Ensure lights are connected and working correctly. Bale damper must be raised to comply with lighting regulations.
- If plastic film is to be transported on the machine it must only be done so on the holders provided and secured, if necessary.
- Ensure the knife guard is closed on the cut and hold, to prevent injury.
- Bale lift arm must be in the fully raised position (if fitted).
- Transport lock must be fitted while travelling on the road. The machine is not suitable for towing at speeds above 40 km/h.

Performing maintenance

- Maintenance and repair work on the machine should always be carried out in accordance with this manual.
- Maintenance and repair work exceeding the content of this manual should only be carried out by qualified persons or your **McHale** dealer.
- When conducting maintenance work tie long hair behind your head. Do not wear a necktie, necklace, scarf or loose clothing when you work near the machine or moving parts. Rotating machinery parts can entangle loose clothing, long hair or dangling jewellery faster than a victim can react. If these items were to get caught, severe injury could result.
- Before working on this machine or altering any setting, the operator must ensure the following:
 - (a) The tractor has definitely stopped moving
 - (b) The hand brake is applied
 - (c) The engine is shut down
 - (d) The ignition key is removed
 - (e) Electronic power supply and control box is disconnected
 - (f) Hydraulic oil supply is switched off

**It is forbidden to open any safety guards or to carry out any work on the machine, unless the above specified precautions have been carried out.*

McHale 991 High Speed Round Bale Wrapper

- When conducting maintenance work always support the machine properly. Where possible, lower the attachment or implement to the ground before you work on the machine. If it is not possible to lower the machine or attachment to the ground, always securely support the machine or attachment. Do not work under a machine that is solely supported by a jack. Never support the machine with props that may break or crumble under continuous load.
- Tyres should be inspected for wear on a regular basis. Tyres should be replaced before wear becomes excessive or after 10 years from the date of manufacture, as indicated on the tyre. Care must be taken when handling tyres. Tyres shall be inflated to the pressures indicated in this manual and on the machine and never over inflated. Tyres shall only be inflated while on the machine or in an appropriate safety cage.
- Never disable any electrical safety circuits, tamper with safety devices or carry out any unauthorised modification to the machine.
- Replace any electrical or hydraulic devices immediately, at the first sign of malfunction or failure, as these components affect the functionality, sequencing and thus safety of operation. Never use a machine where a malfunction exists! Contact your **McHale** dealer to achieve a solution. Always think 'Safety First'!
- Avoid heating near pressurised fluid lines, as pressurised lines can be accidentally damaged when heat goes beyond the immediate flame area.
- Regular clean down is recommended in order to maintain the machine in a safe and reliable working condition. **McHale** recommend that the machine be blown down with an air line, as opposed to a pressure washer, due to the dangers involved with pressure washing and to protect the overall paint work on the machine. If, despite our advice, a pressure washer is used then take extreme caution and operate from ground level only. Never climb onto any part of the machine, while pressure washing, due to the fact that all metal surfaces become extremely wet and slippery and always ensure that the tractor has been shut down, with the ignition key removed.

During inspection

- If on the rare occasion that it is necessary for an inspection to be carried out within the 'Danger Zone' while the machine is running (**extremely dangerous and not recommended!**), there shall be a fully trained and competent second person operating both the tractor and machine controls. The tractor hand brake shall be applied and the electronic control box shall be in manual mode. The machine shall be on level ground with all guards closed. Communication is key. The operator shall inform the inspector before any machine function is activated. The inspector shall remain in the field of vision of the operator at all times and inform the operator of their intended actions. If communication is lost with the operator, or they move within 1.1 m of moving parts or parts that have the potential to move, all tractor power shall be turned off immediately.

Child safety on farms

- All adults working or present on farms are required, by law, to do everything reasonably practical to ensure the safety and health of children and young people on the farm.
- Children must be supervised at all times! Remember, farms are not playgrounds!
- Store farm machinery with safety & stability in mind.
- Always exclude children from potentially dangerous areas (they will often get into apparently inaccessible places). Do not allow them in farm yards on busy days. Contractors should always be made aware of the presence of children.
- Never leave children alone in a tractor cab as they can interfere with controls and many children have been killed falling from the door or rear window of a tractor.
- Children under 16 years of age should never operate power-driven machinery. Keys should be removed from vehicles and controls left in neutral. Lower any implements or loaders to the ground and apply the hand brake.
- Do not allow children to use bales of any description for playing. It is very easy to fall from stacked bales resulting in serious injury, or fall between them leading to suffocation. Make sure there is no evidence of children burrowing under stacked bales.
- Children under 16 should never handle chemicals. Always keep them in their correct containers and securely stored out of sight under lock and key.
- Keep matches in a safe place.

Danger of lightning strike

- If there is a risk of lightning in the area, stop all work.
- If there is a risk of lightning when travelling, find a safe place to pull over and stop the tractor.
- Do not leave the tractor cab or start work until the risk of lightning has passed.

4

Specific safety warnings

4.1 Electronic safety warnings

- This machine is equipped with electronic parts and components which comply to the EMC directive 2014/30/EU but still may be influenced by electromagnetic transmissions of other apparatus, such as welding machines, etc.
- Check electric cables regularly for signs of breakage or wear. If in doubt always replace.
- Do not modify any safety circuits (faulty safety circuits will cause risks).

4.2 Hydraulic safety warnings

- The maximum pressure in the hydraulic system of this machine should not exceed 210 bar.
- Always ensure the system is not under pressure before working on the machine. Oil under pressure can penetrate the skin and cause injury. Beware of pipes under accumulator pressure, depressurise lines by unthreading connections extremely slowly.
- Hydraulically actuated devices must be blocked mechanically against movement, before working on the machine.
- If any hoses are removed or replaced ensure they are marked and re-installed to the correct position during re-assembly.
- Check hoses monthly for signs of leakage or wear. Use a piece of card when checking for leaks. Fine jets of hydraulic fluid can penetrate the skin. Never use your fingers or face to check for leaks. If in doubt always replace. The recommended maximum working time of hoses should not exceed 5 years. Only use exact specification **McHale** genuine replacement parts.
- Do not work on hydraulic systems unless you are qualified to do so. This work should only be carried out by qualified persons or your **McHale** dealer.

4.3 Noise level

- The European directive 2003/10/EC directs employers and employees to control the noise level at work. The noise level at field work may differ according to the tractor, ground, crops and other environmental conditions.
- In normal conditions, whilst driving the machine, the noise level to the driver's ear does not exceed 70 dB (A) with the rear screen of the tractor cabin open. The common noise level of the machine and the tractor is primarily influenced by the tractor noise (radio is an additional noise source). It is recommended to operate this machine with closed cabin windows.

4.4 Fire precautions

- Be aware that crops are easily inflammable.
- Do not smoke or make use of any open fire next to the machine.
- A functioning fire extinguisher should always be available on the tractor.
- The machine is to be kept clear of oil, grease, crops, string, plastic or any other flammable material at all times.
- Do not continue to work with overheated parts, cables or pipes, unless you have identified and eliminated the reason for overheating.
- Equipment being refuelled should have its engine turned off before refuelling. Personnel should be instructed on how to properly refuel equipment: do periodic maintenance checks on the tank, pump, hose and nozzle; and abide by safety rules, such as not smoking when around the refuelling area.



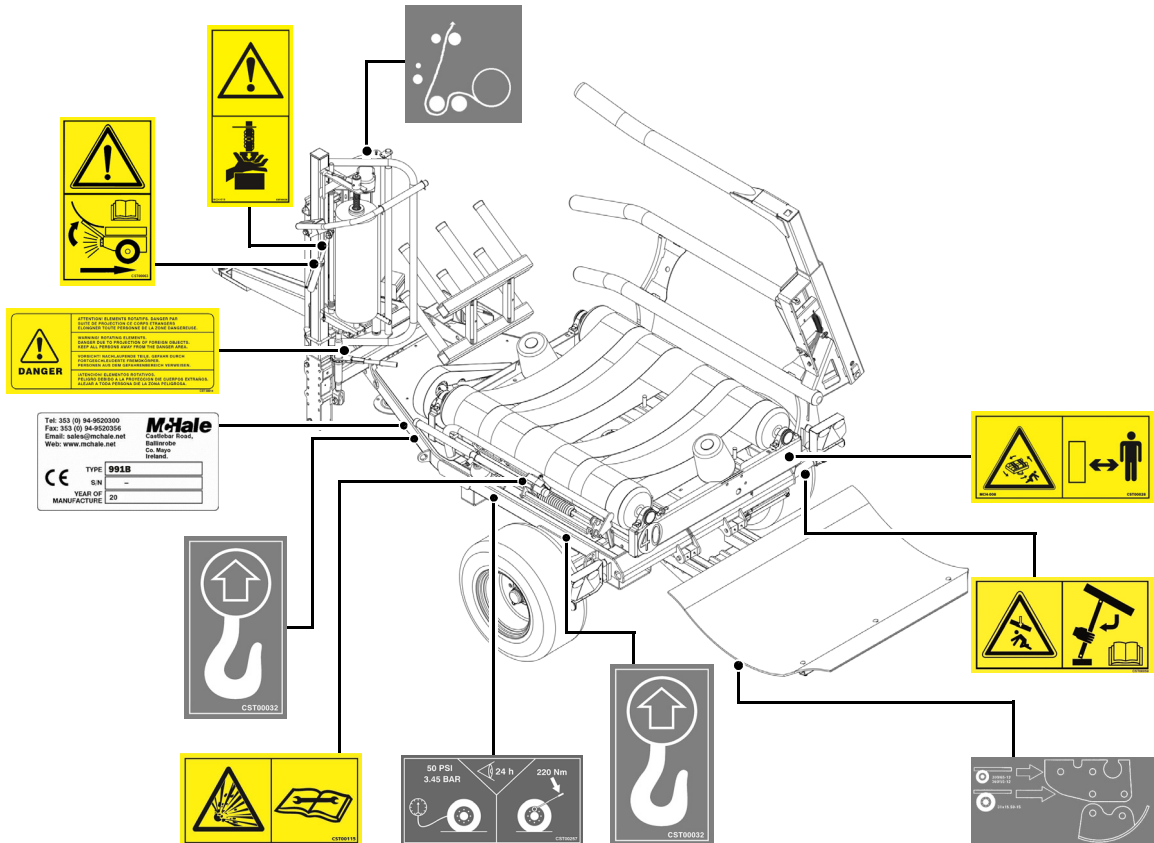
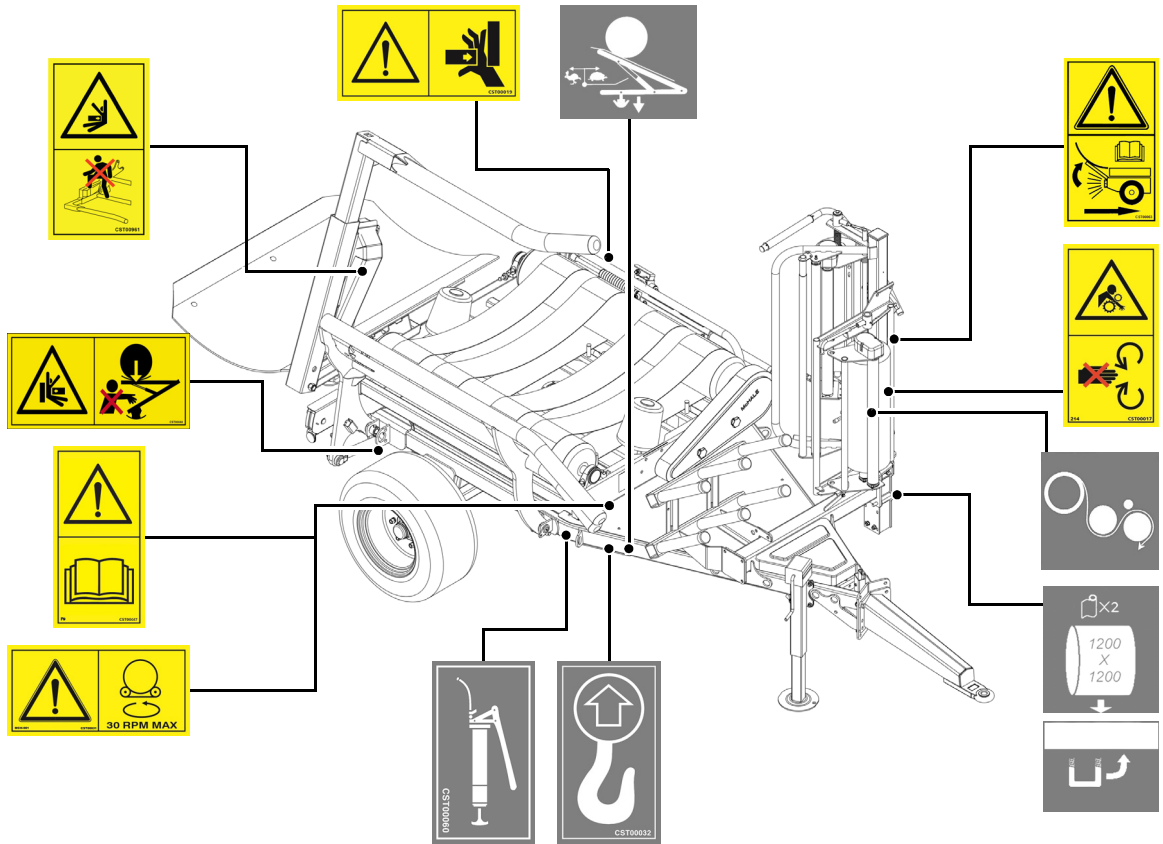

4.5 Safety instruction decal locations



4.6 Safety warnings & instructions explained

Danger areas which cannot be protected by any devices are marked by yellow safety decals. Therefore it has to be ensured that all safety warnings and instructions are understood and followed. If any of the decals are damaged or missing, they are available from your **McHale** dealer. The relevant part numbers are shown in brackets.

The decals featured on the machine are displayed with their meanings below:

	<p>Free flow return to tank (CST00006)</p>
	<p>Danger of rotating parts, foreign objects Keep clear of machine while working (CST00014)</p>
	<p>Turn off and remove key from tractor Read and understand the manual before working on or performing maintenance on the machine (CST00015)</p>
	<p>Keep hands clear of rotating rollers (CTS00017)</p>

McHale 991 High Speed Round Bale Wrapper



Keep hands out of crush area
(CST00019)



Keep hands out of the trap area
(CST00026)



Keep clear of rotating table
(CST00028)



Max table speed 30 rpm
(CST00031)

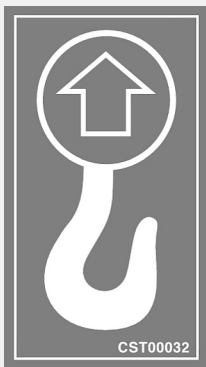

Lifting hook location
(CST00032)



Keep clear of bale damper crush area
(CST00048)

McHale 991 High Speed Round Bale Wrapper

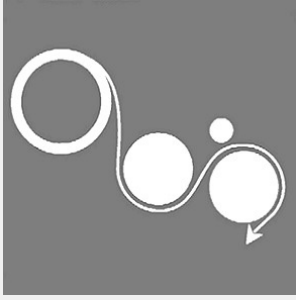
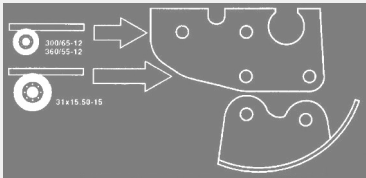

Diagram of plastic film path through dispenser
(CST00049)



Bale damper skid adjustment
(CST00050)



Read instruction manual
(CST00057)



Support table before working under it
Refer to the instruction manual
(CST00059)

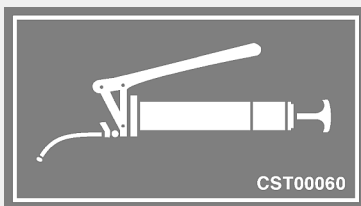

Grease daily
(CST00060)

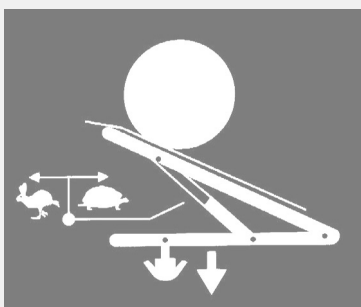

Bale damper drop speed adjustment
(CST00061)

McHale 991 High Speed Round Bale Wrapper



Raise bale damper when lights are being used on the road. (See 'Road traffic safety & operation')
(CST00063)

IMPORTANT
This pin **MUST** be greased immediately after the lift arm is fitted to the machine

Grease pin immediately after fitting the lift arm
(CST00105)

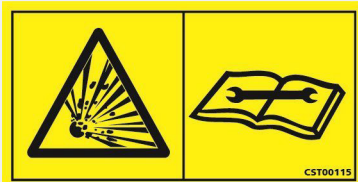

Do not dismantle
High pressure always
(CST000115)

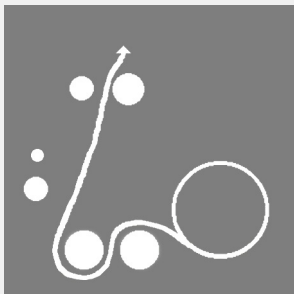
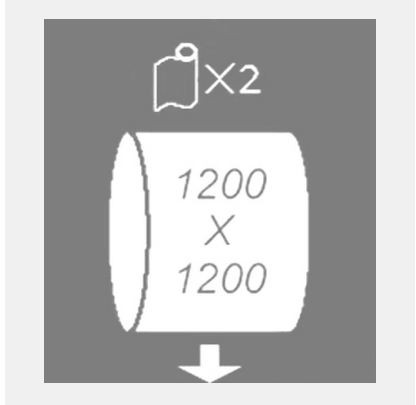

Diagram of plastic film path through rear dispenser.
(CST00191)



Dispenser height setting for front dispenser
(CST0192)

McHale 991 High Speed Round Bale Wrapper



Dispenser height setting, when wrapping with two rolls of film
(CST00193)

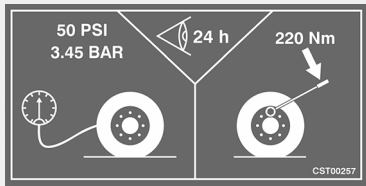

Check tyre pressure
(CST00257)



Tie down points
(CST00901)



Jacking points
(CST00923)



Keep clear of the bale lift arm and auto load paddle, as unexpected movement can occur
(CST00961)

Tel: 353 (0) 94-9520300
 Fax: 353 (0) 94-9520356
 Email: sales@mchale.net
 Web: www.mchale.net

McHale
 Castlobar Road,
 Ballinrobe
 Co. Mayo
 Ireland.

CE TYPE **991**
 S/N -
 YEAR OF MANUFACTURE 20

991 series chassis plate

4.7 Machine lifting guidelines



WARNING: Machine lifting

- Only use chains or strapping that are rated for a minimum load of 0.75 tonnes (750 kg) per chain or strap when using the four lift eye locations on the chassis, shown below
- The crane or lifting device must be capable of lifting a minimum load of 2.5 tonnes (2,500 kg)
- Never go under a suspended machine or attempt to try and stop it, if it is moving erratically, death or serious injury may result
- Always be observant of people and objects around the suspended machine and do not allow the machine to impact heavily on the ground after suspension or movement



RHS front lift hook

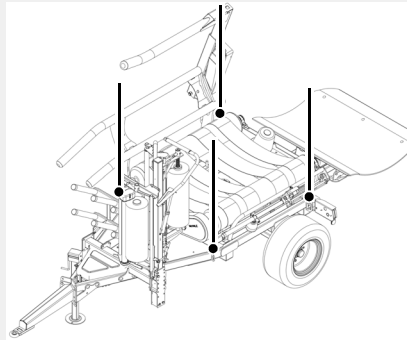

Front view



LHS front lift hook



RHS rear lift hook

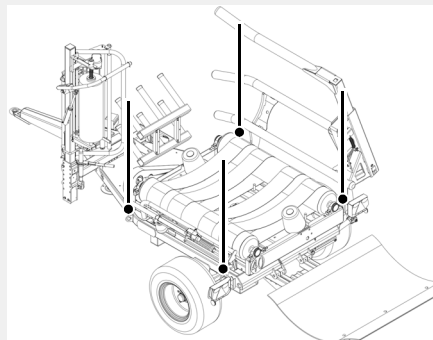

Rear view



LHS rear lift hook

4.8 Jacking guidelines

Jacking points are indicated on the machine with decals. Ensure the machine is on flat solid ground and attached to a tractor. Apply the tractor hand brake, switch off the tractor and remove the key, disconnect the hydraulics and PTO. Use wheel chocks on the opposite wheel to secure against unexpected movement. Suitable well maintained equipment shall be used to raise the machine. Never go under the machine while it is raised off the ground. Introduce the jack from the rear of the machine until it is directly under the jacking area. Slowly raise the jack ensuring that there is solid contact between the jack and the machine before raising off the ground.



WARNING: Do not rely solely on a hydraulic jack!

Ensure the machine is additionally supported with axle stands or equivalent of suitable capacity. Never support the machine with props that may break or crumble under continuous load.

5

Tractor requirements & preparation

5.1 Tractor requirements

The minimum recommended size of tractor for operating the machine comfortably on flat ground would be approximately 35 kW. On hilly ground or difficult conditions, an additional 10 to 15 kW is advisable.



NOTE: Use good quality oil

Ensure that the tractor has clean, good quality, hydraulic/universal oil to avoid problems later on. Also, the hydraulic filters on the tractor should be changed regularly, according to the manufacturer's service instructions. Avoid dirt getting into the hydraulic couplings.

The following items on the tractor are required for attachment of the bale wrapper to the tractor.

1. Drawbar hitch suitable for a vertical load of at least 1,100 kg and a D value of at least 50 kN
2. ½" female quick-release for hydraulic power supply of minimum 20 l/min @ 180 bar
3. ½" female quick-release for return line (must be free flow to tank)
4. 12 V / 7-pin socket for lighting
5. 12 V, 20 A socket or battery power cable (machine loom to control box shown)



5.2 Hydraulic spool valve setup

The wrapper hydraulic valve must be set up in accordance with the type of hydraulic system on the tractor, that is being used. Check the tractor manual or with your dealer if you are unsure of which system is used on the tractor. If in any doubt after checking, use open centre settings as this will not damage the tractors hydraulics. The valve may be set up in two different ways:

1. Plug A (part no CVA06004)
This plug is used for both **open centre** and **load sensing** hydraulic systems. The hydraulic valve is set up to this specification when leaving the factory. When using load sensing hydraulics, always set the tractor oil flow to achieve 30 rpm on the table, using the flow control on the tractors auxiliary valve.
2. Plug B (part no CVA06001)
This setting is used for **closed centre** hydraulic systems.

Changing from plug A to plug B:

- (1) Remove plug A and replace with closed centre plug B
- (2) Tighten the relief valve fully

Changing from plug B to plug A:

- (3) Remove the closed centre plug B and replace with plug A
- (4) Using a pressure gauge, set the relief valve to 250 bar

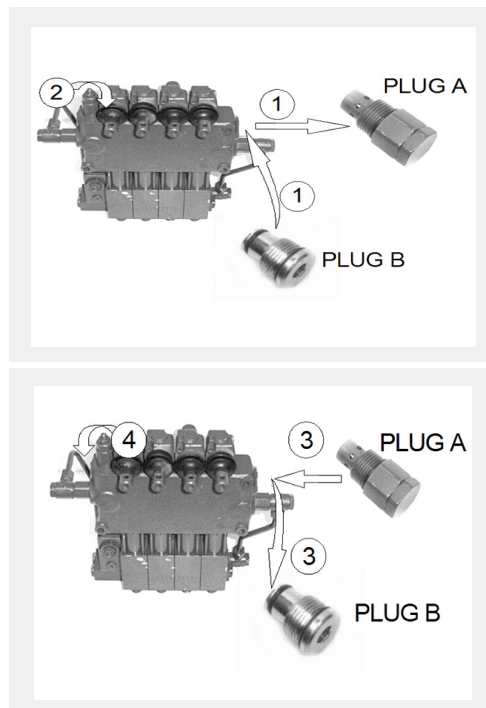

5.3 Attaching the wrapper

1. Reverse the tractor up to the wrapper, lining up the tractor hitch with the wrapper hitch eye.
2. Fit the tow pin to the hitch ensuring it is secure, by inserting a linch pin.
3. Screw the jack up fully off the ground.
4. Plug the hydraulic feed hose into a suitable hydraulic spool valve. Ensure the control valve is correctly configured for the type of hydraulic system on the tractor. (*See 'Hydraulic spool valve setup'*)
5. Plug the hydraulic return hose into a connection that has a freeflow to the tank. It is very important to ensure that it is in freeflow to get the best results from the wrapper.
6. Plug the 7-pin lighting plug into the 7-pin socket on the tractor.
7. Secure the control unit in the tractor cab, using the V-brackets and fasteners provided. If there is no cab on the tractor secure as appropriate, bearing in mind the box is not waterproof.
8. Screw the 37-pin socket on the electronic box and the 37-pin plug on the machine together. Connect the control box to the tractor socket or direct to the battery, using the power cable. There must be a good 12 V supply to the control box!
9. Check that all of the above functions operate correctly.
10. The machine is now ready to work.



Electronic control box

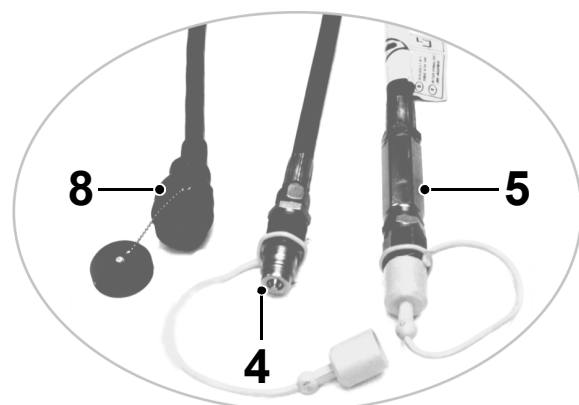

Hoses and cable

5.4 Connecting the control box

The electronic control box must be located inside the tractor cab in the operator's field of vision and within easy reach of the red emergency stop button. (See '*Electronic control system*'). Secure the control unit in the tractor cab, using the V-brackets and fasteners provided. The male half attaches to the control box and the female half attaches to the tractor cab allowing for quick placement/removal, every time it is used. Ensure that the cable to the machine is not under tension and not near sharp edges, etc. The electric power supply is obtained from the socket of the tractor.

Connect the supplied fused electric power lead to the tractor battery ensuring to route away from sharp edges and hot surfaces. The control box is not waterproof, it must be protected from rain.



CAUTION: Do not connect the control box to a 24 V power supply

Do not attempt to connect the control box to a 24 V power supply, as machine component damage will result.

6

Bale & plastic film requirements

6.1 Bale requirements

The bales to be wrapped should be well shaped, dense and of suitable quality for making silage. Substandard material will not produce good quality silage regardless of how well the bale is wrapped.

- Bale width: Up to 1,500 mm wide
- Bale height: Diameter up to 1,500 mm high

6.2 Plastic film requirements

It is of the utmost importance that top quality plastic film is used for wrapping bales. Always follow plastic film manufacturer's recommendations on the storage and use of the film.

It is recommended that a minimum of 4 layers of film are applied to the bale. If the material being wrapped is of a hard or stemmy nature it may be necessary to apply 6 or 8 layers to ensure a good airtight package.

The operator needs to ensure that the bale is correctly wrapped. It is good practice to periodically check the bales after being wrapped for any torn, split or punctured plastic film. If the stubble in a particular field has a tendency to puncture the plastic film, it is strongly advised to wrap the bales at the stack, where there may be more control over ground conditions.

The plastic film must be applied to the centre of the bale. If it is too low or too high adjust the dispenser height as appropriate. (*See 'Dispenser height'*)

To determine the number of table rotations required to wrap a bale, carry out the following procedure:

1. Count the number of table revolutions to cover the bale completely with plastic film.
2. Add 1 to this number.
3. Multiply this resultant figure by 2 (for 4 film layers) or 3 (for 6 film layers)

Example:

- Number of rotations to cover the bale: 7
- Number of rotations to apply 4 layers of film to the bale: $(7+1) \times 2 = 16$



ENVIRONMENT: Recycling of film roll

Respect the environment! Never throw away or burn the waste film or the core tube. Always take waste materials to a recycling centre.

6.3 Care of the film roll

The film roll should be protected from damage and moisture and prolonged exposure to the sun. Do not remove the protective cover until ready for use. Film damage can cause undesired film performance and affect bale weatherability.

McHale 991 High Speed Round Bale Wrapper

This page is intentionally left blank.

7

Electronic control system

(Software Version EXS300-025)

7.1 Electronic control box

The electronic control box is the main interface between the operator and the machine. When the machine is in fully automatic mode, settings must be selected before wrapping commences. It is also possible to work the machine manually through the buttons on the control box.

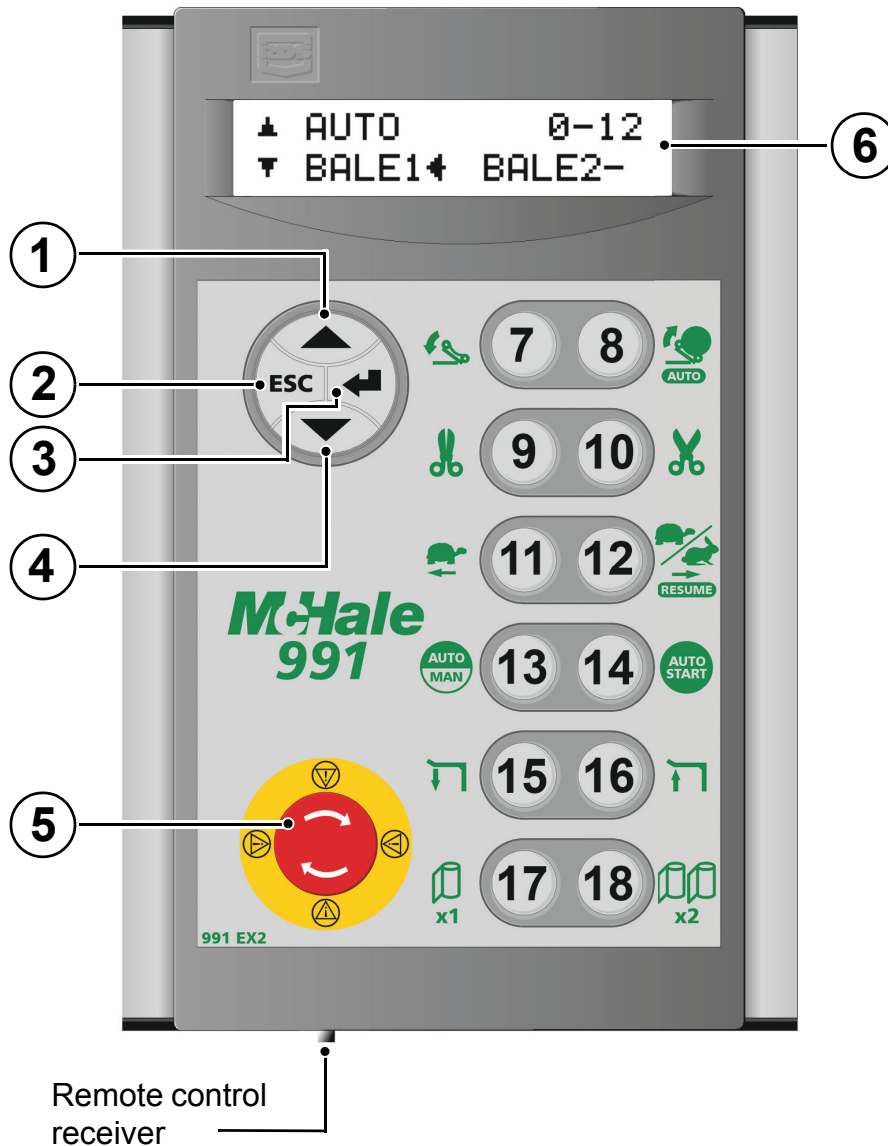

7.2 Electronic control box functions

No.	Function
1	Display Up
2	Press and hold ESC to reset the current wrap count in manual mode
3	Enter
4	Display Down
5	Emergency Stop
6	Display Screen
7	Table lower If Continuous is set to On then press button 7 during wrapping to prevent automatic tipping of individual bales. (Useful on hills)
8	Table tip (In Automatic Mode, it starts the tipping part of the cycle)
9	Cut & hold close
10	Cut & hold open
11	Table reverse (slow)
12	Table forward (slow/fast) Press the button for slow speed, release & quickly press it again for fast Resume: Restarts the wrapping or any other interruption. One press of this button during wrapping will engage the slow speed. Pressing again will resume full rotation speed.
13	Automatic/Manual mode
14	Automatic cycle start. If 'Auto Load' is set to On or Semi then press and hold AUTOSTART to re-wrap. (Skips the loading sequence)
15	Bale lift arm down
16	Bale lift arm up
17	Hold for 3 seconds to select "1 roll of film" mode
18	Hold for 3 seconds to select "2 rolls of film" mode

7.3 Available wrapping programs

The following list shows the list of wrapping programs that are available. The items that are greyed out are not used/available on this machine. (See 'Wrapping sequence/program')

Program	Description	Table start position
991 BE Standard o	991 BE, 991 BER standard field operation	Cut & hold at left side of the machine
Combi trailed oo	Not used on 991 B series/ 991 L series	
Combi standard IL	Not used on 991 B series/ 991 L series	
Remote r97L	991 LBER with bale lift arm	Cut & hold at the left side of the machine
Remote r94	991 LBER standard	Cut & hold at the front of the machine
991 BE Remote rt	991 BER remote control operation	Cut & hold at the front of the machine
Remote r	Program not in use	
Side Load Remote	991 LBER side load	Cut & hold at the left side of the machine
High Speed	High Speed	Cut & hold at the left side of the machine
High Speed Remote	High Speed Remote	Cut & hold at the front of the machine

7.4 Electronic control box setup

991 MENU STRUCTURE EXS300-025

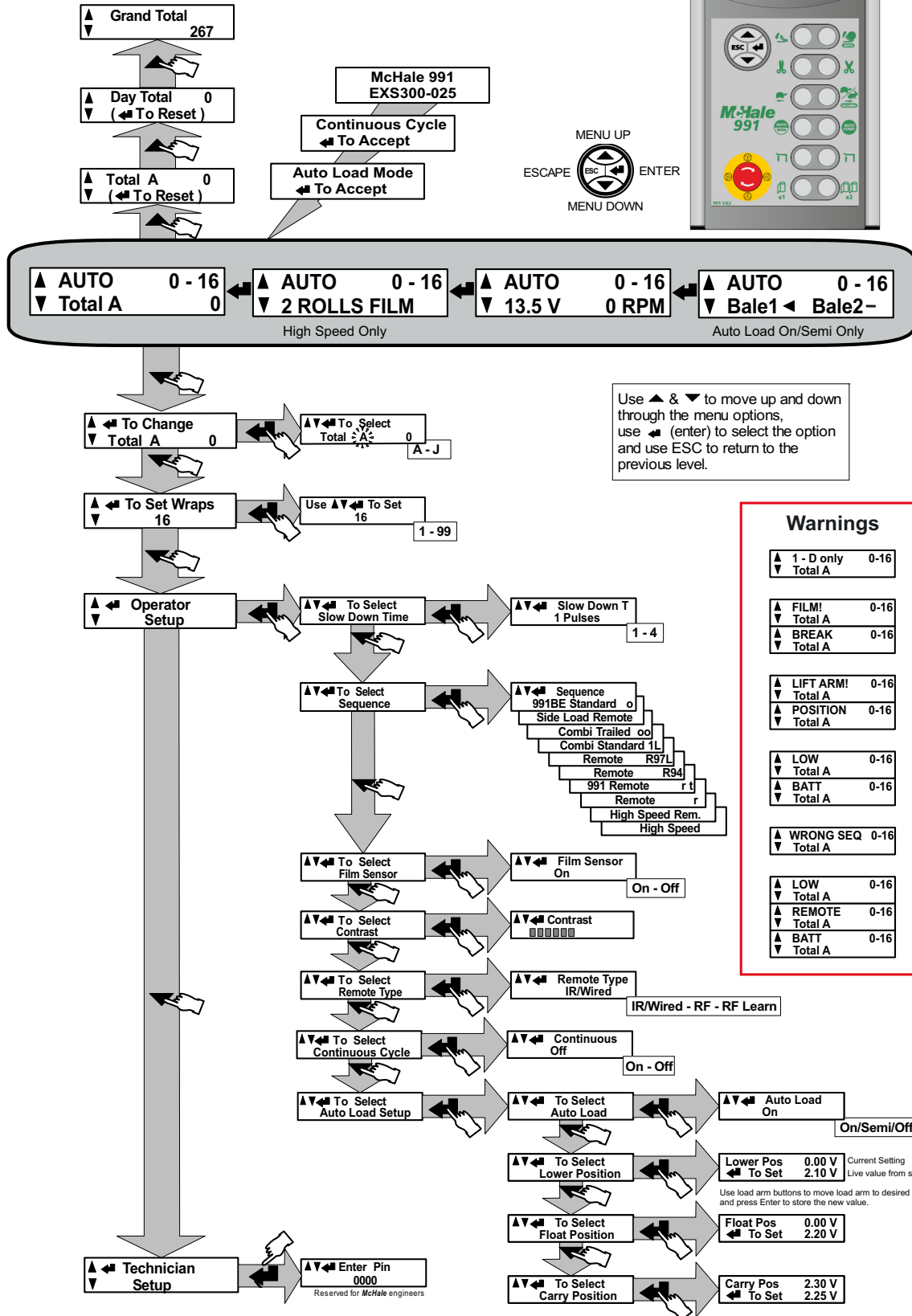

7.5 Electronic control box features

7.5.1 Working display

When the electronic control box is first switched on it displays “Expert Series”, with the software version number beneath.



NOTE: Continuous Cycle and Auto Load sequence “ON” settings must be confirmed every time

Every time the electronic control box is turned on Enter (Button 3) must be pressed to confirm the Continuous Cycle (*See ‘Continuous cycle’*) and Auto Load Setup (*See ‘Auto load setup’*), if these were previously set to on. If you don’t press Enter for each sequence, it will default the setting to OFF!

After a short delay the working display (Screen 1 of 4) appears. Press Enter (Button 3) to toggle between the screens. The working display contains two lines:

1. The upper line displays the machine status i.e. manual or automatic, the current wrap count and the target number of wraps. The upper line remains constant in all screens.
2. The lower line changes in each of the working display screens, as follows:
 - (a) Screen 1 displays the current bale counter and its counter total
 - (b) Screen 2 indicates whether 1 roll of film or 2 rolls of film mode is selected
 - (c) Screen 3 displays the voltage and the table speed in rpm
 - (d) Screen 4 indicates whether there is a bale on the wrapper (BALE 1) and a second bale being carried on the load-arm (BALE 2).

Screen 4 is only available if Auto Load is set to On or Semi. Screen 4 indicates with an arrow whether there is a bale on the wrapper (BALE 1) and a second bale being carried on the load arm (BALE 2).

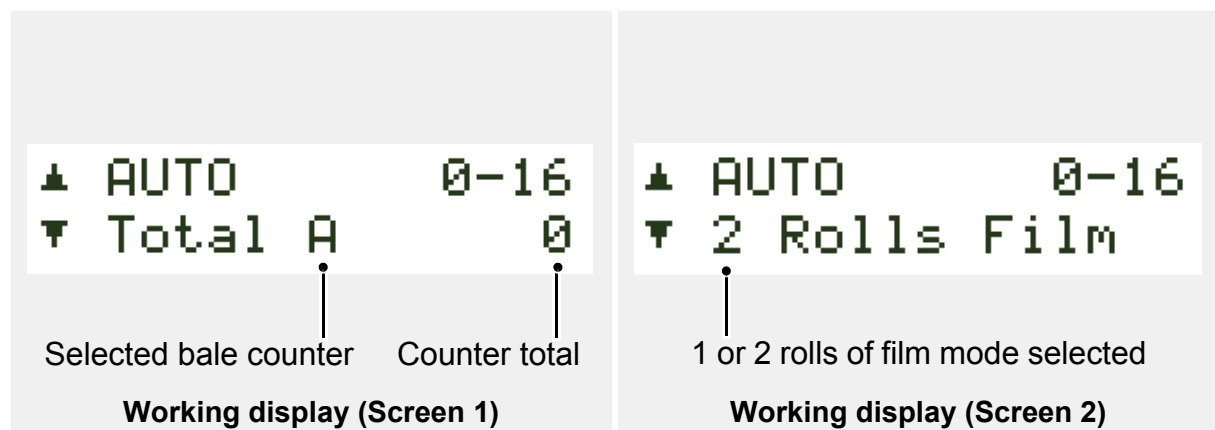

McHale 991 High Speed Round Bale Wrapper

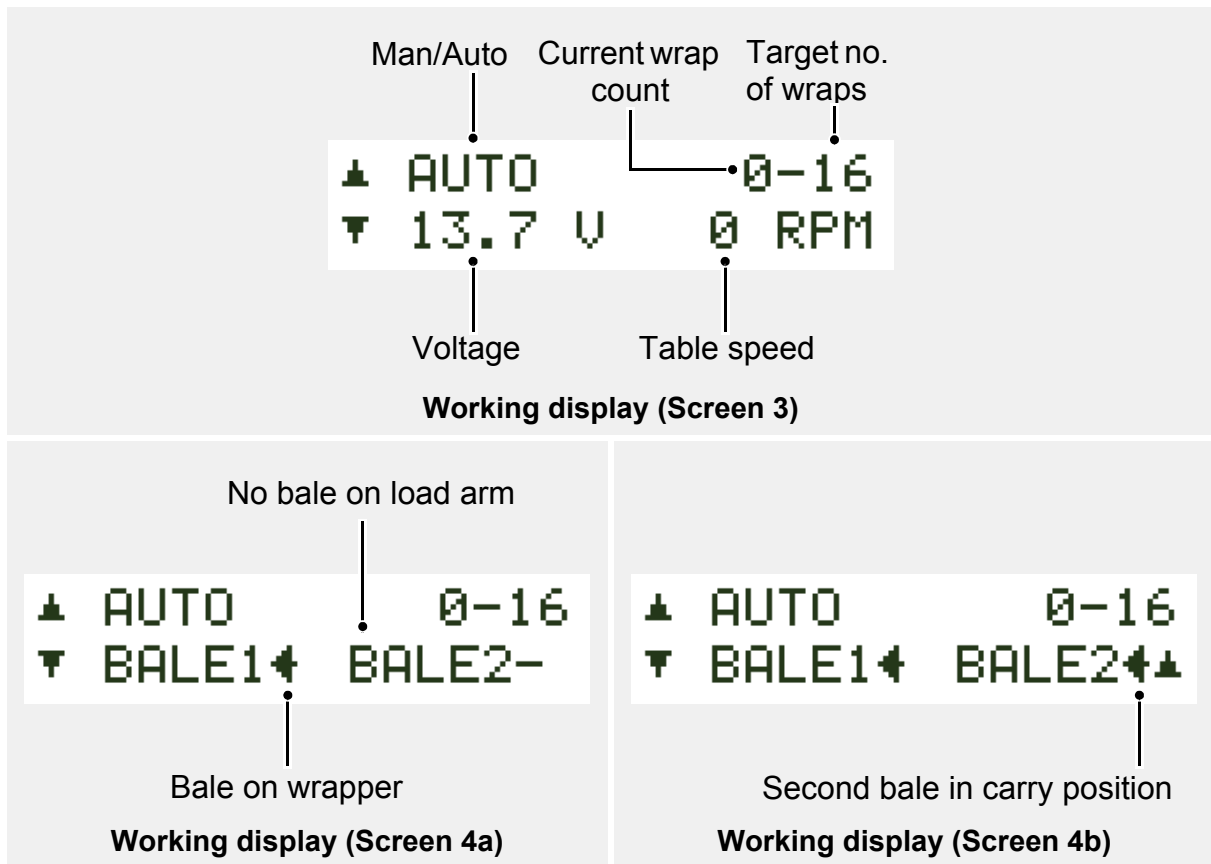

A solid left arrow beside BALE1 indicates there is a bale on the wrapper. A flashing left arrow beside BALE1 indicates wrapping has been interrupted and incomplete. Press RESUME to continue wrapping.

A solid left arrow beside BALE2 indicates that the load-arm is in the carry position. A solid left arrow and a flashing up arrow indicates that BALE2 will automatically load when BALE1 is tipped off. A flashing up or down arrow beside BALE2 indicates the direction the load-arm will travel when AUTO START is pressed.

7.6 Counters

The Expert Series Electronic Control Box contains the following counters:

- **Ten different bale counters (A - J)**, which can be reset. These bale counters can be used to measure the amount of bales wrapped for various customers by using a different counter for each customer.
- **Day Counter**, which can be reset. Every bale wrapped by the machine is added to the day total count regardless of the customer counter that is currently selected. It can be reset at the start/end of every day.
- **Grand Total Counter**, which cannot be reset. Every bale that is wrapped by the machine is added to this counter.

Select & set a bale counter (A-J)

1. From the working display, press the Display Down (Button 4) once to select To Change Total
2. Press Enter (Button 3) to move to the To Select Total “X” display
3. Select desired counter (A -J) using the Up and Down Arrows (Buttons 1 & 4)
4. When you reach your desired counter press Enter (Button 3) to select it
5. Press the Up Arrow (Button 1) or ESC (Button 2) once to return to the working display

Reset the current bale counter (A-J)

1. Press the Up Arrow (Button 1) once, from the working screen
2. The current bale counter total will be displayed
3. Press Enter (Button 3) to reset it
4. Press the Down Arrow (Button 4) or ESC (Button 2) once to return to the working display

View the day total bale counter

1. Press the Up Arrow (Button 1) twice, from the working screen
2. The day total counter will be displayed
3. Press the Down Arrow (Button 4) or ESC (Button 2) twice to return to the working display

Reset the day total bale counter

1. Press the Up Arrow (Button 1) twice, from the working screen
2. The day total counter will be displayed
3. Press Enter (Button 3) to reset it
4. Press the Down Arrow (Button 4) or ESC (Button 2) twice to return to the working display

View the grand total bale counter

1. To view the grand total bale counter, press the Up Arrow (Button 1) three times, from the working screen
2. The grand total counter will be displayed
3. Press the Down Arrow (Button 4) or ESC (Button 2) three times

7.6.1 Voltage monitor

The “Expert Series” Electronic Control Box monitors its operating voltage and displays it during wrapping. If the voltage falls below a safe level “LOW BATT” is flashed on the display. The usual causes of low voltage are:

- A bad battery
- A defective charging circuit
- Loose or corroded connections
- Fuses or a faulty power lead to the control box

7.6.2 Liftarm position

The lift arm must be down before a cycle can be started. If not then a 'Liftarm Position' warning is displayed.

7.6.3 To set wraps

To change the desired/target number of film wraps:

1. Press the Down Arrow (Button 4) twice, from the working screen, to display the To Set Wraps Screen
2. Press Enter (Button 3) to move to the Use To Set Screen
3. Use the Up and Down Arrows (Buttons 1 & 4) to make changes. When the target number of wraps is displayed, return to the working display by pressing ESC (Button 2) twice.

7.6.4 Operator setup

To enter the Operator Setup Menu:

1. Press the Down Arrow (Button 4) three times from the working screen
2. Press Enter (Button 3) to move to the Operator Setup options:
 - Slow Down Time
 - Wrapping Sequence/Program
 - Film Sensor
 - Display Contrast
 - Continuous Cycle
 - Auto Load Setup
 - Remote Type
3. Use the Up and Down Arrows (Buttons 1 & 4) to select an item, press Enter (Button 3) to adjust the current selection/setting.

Slow down time

This setting determines when the table goes into slow down speed at the end of a wrapping cycle. The adjustment range is from 1 to 4 sensor pulses. (There are 2 sensor pulses per table revolution). To change the slow down time:

1. Press the Down Arrow (Button 4) three times
2. Press Enter (Button 3) once to move to the Select Slow Down Time Screen & press Enter again to adjust the setting
3. Use the Up and Down Arrows (Buttons 1 & 4) to change the value, press Enter (Button 3) to save the new setting.

Wrapping sequence/program



CAUTION: Select the correct wrapping sequence before using the machine

The “Expert Series” Electronic Control Box is designed to control a number of different **McHale** wrapping machines, therefore, it is very important that the correct wrapping sequence be selected to suit the machine in use, before work begins.

It is crucial that the correct wrapping sequence/program is selected for the **991 High Speed**. (See ‘Available wrapping programs’)

To change the wrapping sequence/program:

1. Press the Down Arrow (Button 4) three times
2. Press Enter (Button 3) once
3. Press the Down Arrow once and press Enter again
4. Use the Up and Down Arrows (Buttons 1 & 4) to select a sequence, press Enter (Button 3) to save a new sequence/program.

Film sensor

The film sensor monitors the passage of film through the dispenser rollers. If one roll breaks or empties then ‘1 Dispenser’ warning will be displayed. If the roll empties or the film breaks, “FILM BREAK” will be flashed on the display and the wrapping table will rotate forward in slow speed and pause briefly. The table then rotates slowly in reverse to a position before the film breakage and waits for the film to be replaced. The operator must apply the parking brake, switch off the tractor and remove the key before replacing the film roll and attaching the film to the bale. When the tractor is restarted, press “Resume” (Button 12) to complete the wrapping.

Film sensors are normally turned “On”, but can be switched “Off” from the Operator Setup Menu, if film sensing is not desired or if there is a problem with a sensor. To set the sensor On/Off:

1. Press the Down Arrow (Button 4) three times
2. Press Enter (Button 3) once
3. Press the Down Arrow twice to move to the Select Film Sensor Screen and press Enter
4. Use the Up and Down Arrows (Buttons 1 & 4) to adjust the setting i.e. On/Off
5. Press Enter (Button 3) to save the new setting

If the operator wants to continuously operate the machine with only 1 single roll of film, they should select the “1 roll of film” mode, by pressing Button 17 and holding it for 3 seconds. A short beep will sound and “1 roll film” will be displayed on the screen. This mode doubles the target count and reduces the bale indexing speed to half, so that the machine can be operated the same as a standard single dispenser 991 BE machine. The film must then be loaded onto the lower dispenser unit only (See ‘Loading plastic film’) and the dispenser height must be set to its highest position (See ‘Dispenser height’).

McHale 991 High Speed Round Bale Wrapper

To go back to normal twin dispenser operation, Button 18 must be held pressed for 3 seconds until “2 rolls film” is displayed on the screen. The dispenser height must be returned to its lowest position (See ‘Dispenser height’).

Display contrast

Extremes of temperature may affect the contrast of the display which is adjustable from the contrast menu. To adjust the contrast:

1. Press the Down Arrow (Button 4) three times
2. Press Enter (Button 3)
3. Press the Down Arrow (Button 4) three times and press Enter
4. Use the Up and Down Arrows (Buttons 1 & 4) to adjust the setting
5. Press Enter (Button 3) to save the new setting

Remote type

This option is used to select the remote control type. There are 3 different types used:

- Wired remote
- Infrared (IR) - Older machines
- Radio frequency type (RF) - Newer machines

To select the remote type:

1. Press the Down Arrow (Button 4) three times, to select the Operator Setup Menu
2. Press Enter (Button 3)
3. Press the Down Arrow (Button 4) four times and press Enter
4. Select either IR/WIRED, RF or RF Learn as appropriate
5. Press Enter (Button 3) to save the selection

Wired remote

Whenever the wired remote is being used, select IR/WIRED in the Remote Type Menu as above. Connect the wired remote to the serial port on the electronic control box and select Auto mode. The cycle can be started using the Auto Start button. The Emergency Stop button will stop the cycle at any time. The other two buttons will raise and lower the load arm.

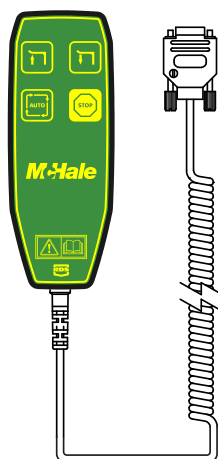

Wired remote

McHale 991 High Speed Round Bale Wrapper

Infrared remote

Whenever an Infrared remote type is being used, select IR/WIRED in the Remote Type Menu, as above. Connect the receiver to the serial port on the electronic control box and select Auto mode (Button 13). The cycle can be started by pointing the infrared remote at the receiver and pressing the Auto Start Button. The Emergency Stop Button will stop the cycle at any time. The other two buttons will rotate the table in forward and reverse.

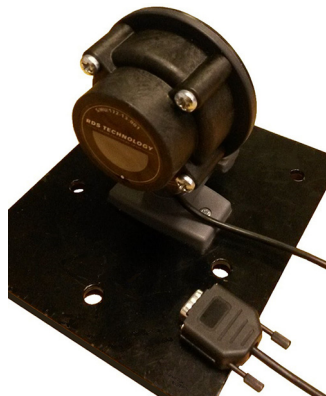

Infrared receiver

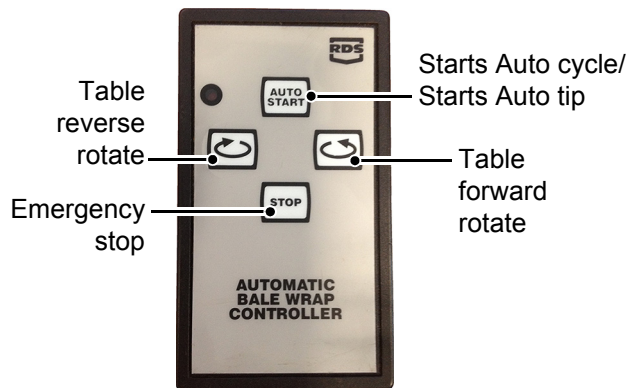

Infrared remote

Radio remote

Whenever a radio remote is being used for the first time, the remote frequency code must be “learned” by the electronic control box. Select “RF LEARN” in the Remote Type Menu and connect the receiver to the serial port on the electronic control box and select Auto mode (Button 13). Press the Stop Button on the radio remote. A code will appear on the screen of the electronic control box to show that the radio frequency code has been stored. ESC (Button 2) can then be pressed to return to the working screen and the remote is ready to use.

This procedure only needs to be followed when the remote handpiece is used with an electronic control box for the first time. The “RF” type will be automatically used once the remote frequency code has been established. Up to 7 handpieces can be programmed into the one electronic control box, if desired. Each remote handpiece has a different code which ensures that multiple wrappers can operate in the same location, without interfering with each other.



CAUTION: Press the safety button on the radio remote simultaneously with all function buttons, except for Stop

There is a safety button located on the back of the remote which needs to be pressed simultaneously with each function button to activate it. This safety button doesn't need to be used for the Stop Button.

McHale 991 High Speed Round Bale Wrapper



WARNING: Radio remotes have a very long range, do not accidentally press any buttons when not near the machine

There is a very long range with radio remotes (approx. 200 metres in the line of sight), so care must be taken not to accidentally press any buttons even when not near the machine. The control box must be in AUTO mode before any remote functions will work.

With either remote type, pressing the “Table Forward Rotate” Button on the handpiece during wrapping will switch On/Off a 12 volt output on one of the spare electrical connectors on the wrapper wiring loom. This feature can be used to switch on an external valve on a hydraulic power pack to select a lower oil flow setting (This is useful when wrapping badly shaped bales).

If the battery is low on the radio remote and a button is pressed then a LOW REMOTE BATT warning will be displayed and the control unit will switch to manual mode.

There is a spare connector on the wrapper wiring loom marked with the letter “E”. (On machines up to serial no. 58297 the white/blue wire is +12 volts and the yellow/green is ground). (On machines from serial no. 58298 the brown wire is +12 volts and the yellow/green is ground).

The maximum current available on this 12 volt output is 3 amps.



NOTE: This equipment has been tested and found to comply with the limits for a Class A digital device, pursuant to part 15 of the FCC Rules

These limits are designed to provide reasonable protection against harmful interference when the equipment is operated in a commercial environment.

This equipment generates, uses, and can radiate radio frequency energy and, if not installed and used in accordance with the instruction manual, may cause harmful interference to radio communications.

Operation of this equipment in a residential area is likely to cause harmful interference in which case the user will be required to correct the interference at his own expense.

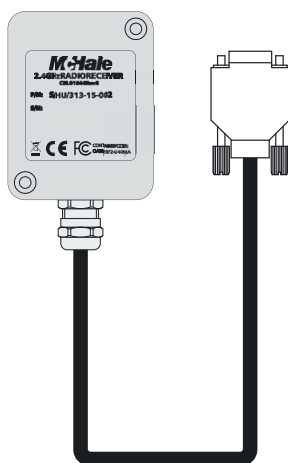

Radio receiver

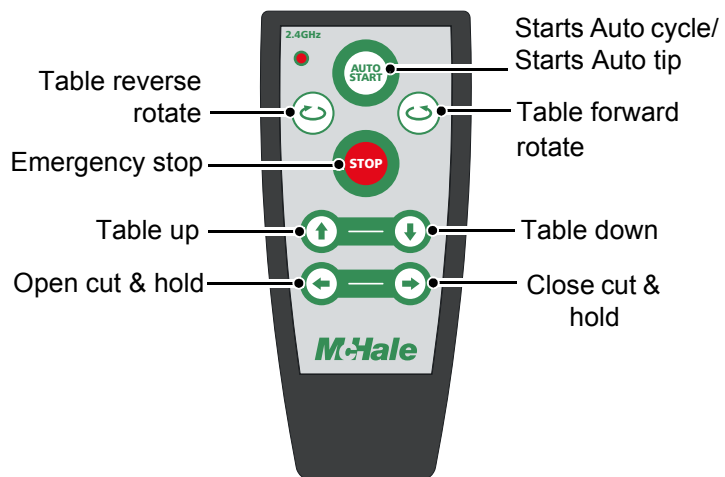

Radio remote

Continuous cycle

The Continuous Cycle, when enabled, allows the wrapping machine to complete the wrapping cycle without waiting for the operator to press Table Tip (Button 8) to start the tipping part of the cycle. Every time the electronic control box is switched on, it asks the operator to press Enter (Button 3) to confirm that the Continuous Cycle is required.

If Continuous is set to On then press button 7 during wrapping to prevent automatic tipping of individual bales.



CAUTION: Do not use the continuous cycle on hilly terrain

The continuous cycle should not be used in hilly terrain as the operator needs better control of bale unloading i.e. the bale should be unloaded on level ground.

To turn the continuous cycle On/Off:

1. Press the Down Arrow (Button 4) three times, to select the Operator Setup Menu
2. Press Enter (Button 3)
3. Press the Down Arrow (Button 4) four times and press Enter
4. Use the Up and Down Arrows (Buttons 1 & 4) to select On/Off
5. Press Enter (Button 3) to save the new setting

Auto load setup

The Auto load feature, when enabled in the operator menu allows for automatic loading of the bale. There are two modes for Auto load: 'Semi' or 'On'.

- If set to 'Semi' then the operator must use the AUTO START button to control the automatically loading sequences.
- If set to 'On' then automatic loading is controlled using the paddle sensor on the load-arm. (The AUTO START button can also be used if necessary).

The load arm has three positions: 'Lower', 'Float' and 'Carry'. After loading a bale the load-arm will sit at the float position. If the 'Float Position' is set to higher than the lower position then upon approaching the bale, AUTO START (Button 14) is pressed, the load-arm drops to the preset lower position and the machine is moved forward to receive the bale.

If 'Auto load' is set to 'Semi' then AUTO START is pressed again; the load-arm lifts the bale onto the wrapping table, the arm lowers to the float position and wrapping starts.

If 'Auto load' is set to 'On' then when the bale hits the auto-load paddle (if fitted) the load-arm lifts the bale onto the wrapping table, the arm lowers to the 'Float Position' and the wrapping starts.

If there is a bale already on the wrapper then a second bale can be carried on the load-arm.

If 'Auto Load' is set to 'Semi' then AUTO START is pressed again to lift the second bale into the carry position.

McHale 991 High Speed Round Bale Wrapper

If 'Auto load' is set to 'On' then when the bale hits the auto-load paddle the load-arm raises into the carry position. The second bale loads automatically when the first bale is tipped off.

The lower, float and carry positions may be adjusted to suit the terrain and bale size.

1. Press the Down Arrow (Button 4) three times. 'Operator Setup' will be displayed.
2. Press Enter (Button 3) to access the 'Operator Setup' menu
3. Press the Down Arrow five times. 'Auto Load Setup' will be displayed.
4. Press Enter to access the 'Auto Load Setup' menu
5. Press the Down Arrow (Button 4) and scroll through the options to select 'Lower Position' or 'Float Position' or 'Carry Position'
6. Press Enter to access each setting
7. Using the 'Bale lift arm down' (Button 15) and 'Bale lift arm up' (Button 16), move the arm to the desired position ('Lower'/'Float'/'Carry') When it is correct, press Enter (Button 3) to store the setting for the current position and press ESC (Button 2) to return to the 'Auto Load Menu'
8. When the three settings are correct, select 'Auto Load' in the menu and set to 'On' or 'Semi' as required.
9. Press ESC to return to the working screen.

More accurate settings can be achieved if the adjustments are done as the arm is moved from a higher to a lower position. Every time the electronic control box is switched on the operator must press Enter (Button 3) to confirm that the 'Auto Load Cycle' is required.



Auto-load paddle (fitted from Serial No. 63792)



WARNING: Safety regarding the 'Auto-load' paddle

Ensure that the tractor engine has been shut down and the ignition key has been removed, if the driver is leaving the tractor cab. Never go near the lift-arm or paddle with the tractor running, as sudden movement can occur especially in Auto mode.

7.6.5 Technician menu

The technician menu is reserved for **McHale** engineers only. A pin code needs to be entered to access the menu.

8

Wrapper operation



WARNING: Keep out of the 'Danger Zone'

Keep all persons outside of the 'Danger Zone' during all machine operations! (See 'Danger Zone')



ENVIRONMENT: Recycling of the plastic film

Respect the environment! Never dump or burn waste plastic film. It's toxic! Always take waste materials to a recycling centre.

8.1 Preparing the machine for wrapping

1. Load the plastic film into the dispenser running it through the rollers. Attach the film to the bale. (See 'Loading plastic film')
2. Turn on the oil supply.
3. Unlock the transport lock. Do not attempt to lower the bale lift arm with the transport lock still engaged.
4. Lower the bale lift arm to the ground.
5. Lower the bale damper.
6. Switch on the electronic control box and set to 'Automatic' mode.
7. Ensure the table is in the correct starting position. (See 'Electronic control box functions'). The control box needs to be set on "manual" to work this function.
8. The machine is now ready to wrap.



Transport lock, unlocked

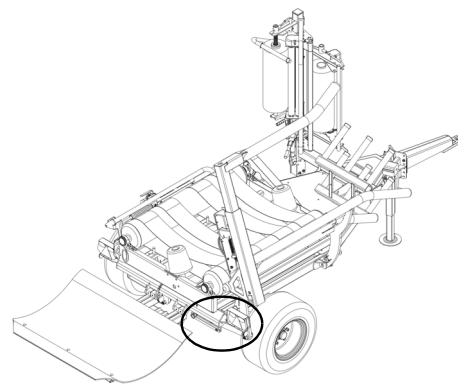

991HS machine

8.2 Loading plastic film

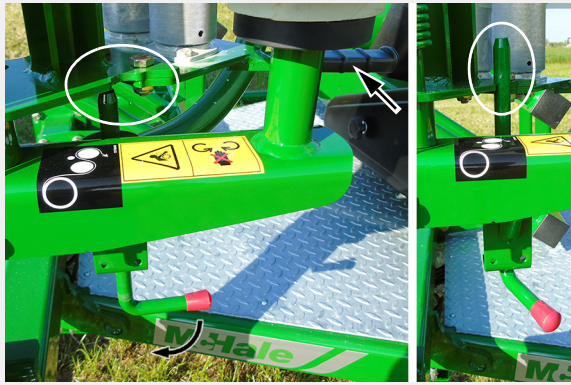

1. Push back the handle until the dispenser latches open. (Upper dispenser only)



2. Pull back the handle until the dispenser latches open. (Lower dispenser only)



3. When removing an old roll, push upwards to latch the top roll holder in the 'up' position. Then remove the old roll core and dispose of it responsibly.

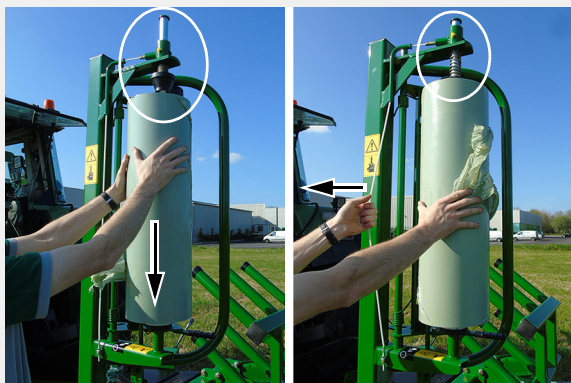

4. Sit the new roll onto the bottom roll holder and align it with the top roll holder.

While still holding the roll, pull the cable to release the top roll holder. The roll of plastic film is now held in position.

McHale 991 High Speed Round Bale Wrapper

Upper dispenser threading path

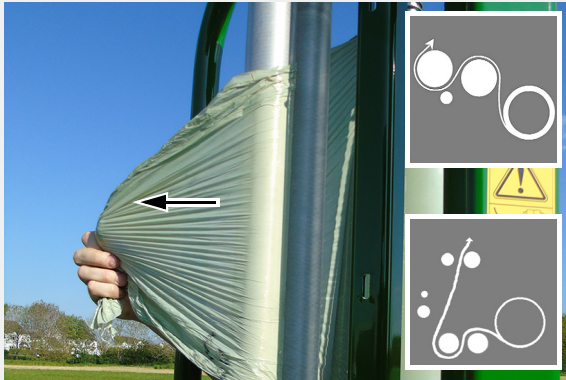

Lower dispenser threading path

5. Thread the film through the dispenser rollers, as per the threading diagrams for the upper or lower dispenser.



6. Pull approximately 1.5 m of film away from the dispenser and make a knot at the end of the plastic film. Slide the knotted end of the film in the slot provided, as shown. Never attempt to clamp plastic film in the cut & hold mechanism.

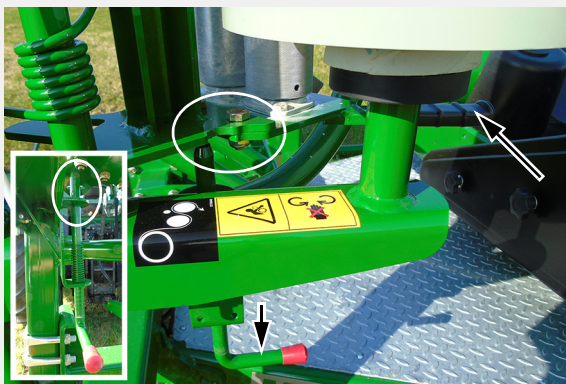

7. Close the dispenser by releasing the latch. The roll should now rest against one of the aluminium rollers. (Upper dispenser only)



8. Pull back the handle, with force and push up on the dispenser latch and then release the handle. (Lower dispenser only)

McHale 991 High Speed Round Bale Wrapper



WARNING: Do not clamp film in the 'cut & hold' mechanism

Do not attempt to clamp plastic film in the 'cut & hold' mechanism as this action may result in serious injury!



CAUTION: Use protective gloves

Use protective gloves for any manual work in this area! Beware of sharp knife edges.

The cut and hold knife guard must be swung open before starting to wrap; otherwise the film will not get cut within the cut and hold. Always close the knife guard after work is complete, as the knife is really sharp! Use protective gloves and beware of sharp knife edges!

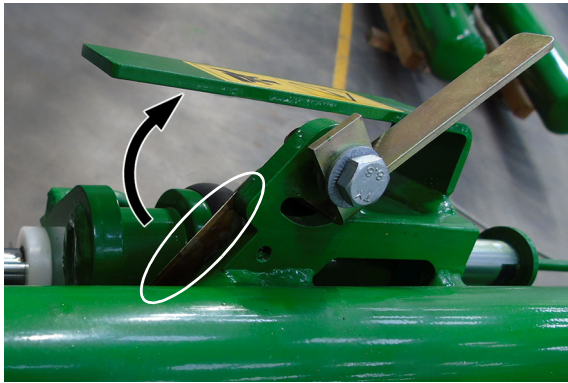

Knife guard open

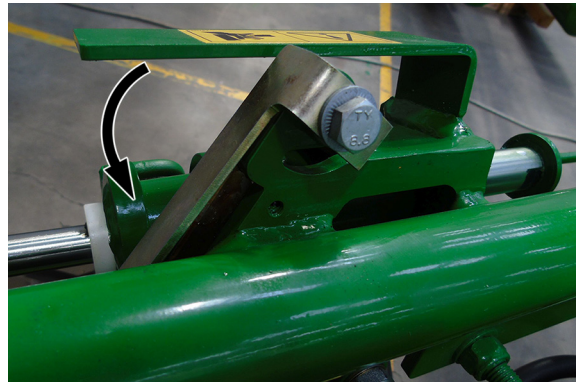

Knife guard closed

8.3 Dispenser gears

The dispenser rollers are set for a standard film stretch of 70%. Optional sets of dispenser gears for both 55% and 64% film stretch are available from your **McHale** dealer. One kit (A) is necessary for each dispenser on the machine.

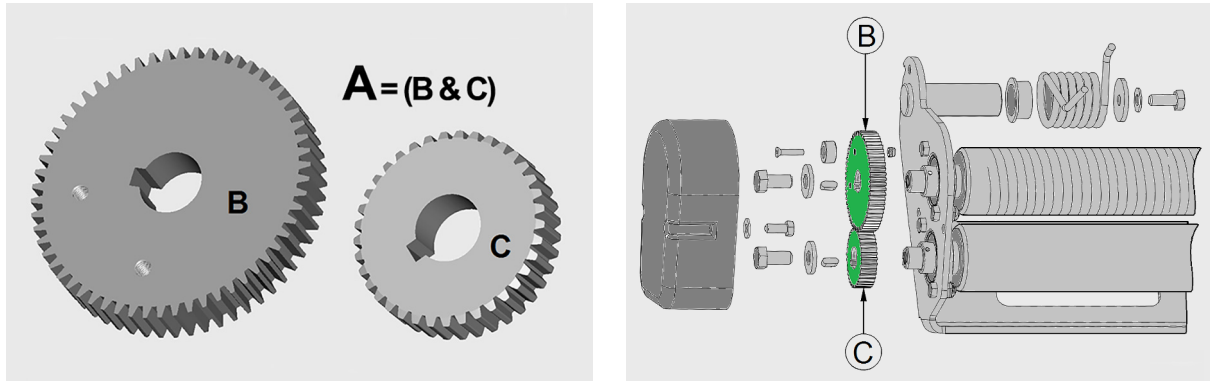

70% Gear option

Item	Part Code	Description
A	ADP00018	Kit dispenser gears 70%
B	CMH00055	Gear spur 1.5 m 60 t dispenser
C	CMH00175	Gear spur 1.5 m 35 t dispenser

64% Gear option

Item	Part Code	Description
A	ADP00020	Kit dispenser gears 64%
B	CMH00056	Gear spur 1.5 m 59 t dispenser
C	CMH00096	Gear spur 1.5 m 36 t dispenser

55% Gear option (Hot climates)

Item	Part Code	Description
A	ADP00019	Kit dispenser gears 55%
B	CMH00057	Gear spur 1.5 m 58 t dispenser
C	CMH00174	Gear spur 1.5 m 37 t dispenser

8.4 Side-tip bale damper

The **991 High Speed** may be used in conjunction with a side-tip bale damper instead of the standard bale damper. The side-tip bale damper may be used as a standard bale damper or with one adjustment to enable it to tip the bales on their ends. To change from standard tipping to side tipping the following is carried out.

1. Be extremely careful when working with the side-tip bale damper.
2. Hinge up the bale damper cradle plate ensuring it is secure and cannot fall.
3. Remove the large linch pin and pull the support arm out on the shaft.
4. Turn the support arm through 90 degrees (pointing upwards) and push the support arm back into place. Secure it with the large linch pin.
5. Lower the bale damper cradle plate down again.
6. The machine is now ready to side tip bales. When side tipping bales, the machine must be stopped during tipping.
7. Reverse this procedure to change back to normal tipping. The side-tip rear extension piece must be removed for normal tipping, if fitted.

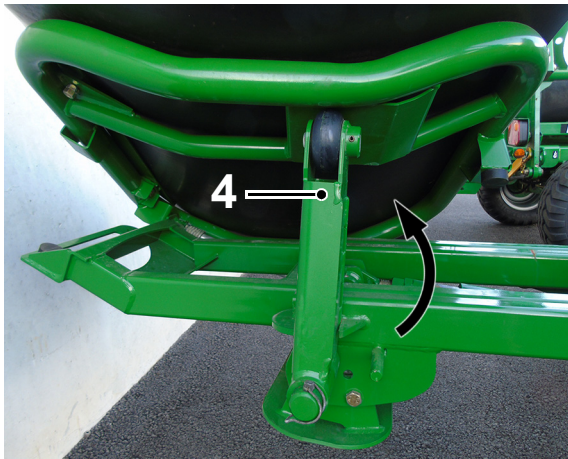

Side-tip active

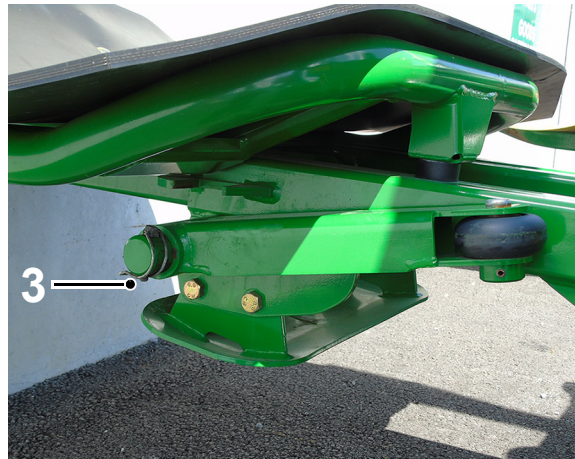

Side-tip inactive

8.5 Wrapping behind the tractor

The following is the recommended method for working the **991 High Speed** after a tractor. It assumes the bales are well shaped for wrapping. However since it is impossible to allow for all differing conditions and terrain it may be necessary for the operator to vary this.



WARNING: Keep out of the 'Danger Zone'

Keep all persons outside of the 'Danger Zone' during all machine operations! (See 'Danger Zone')

The electronic control box should be set to program "High Speed" (Select "1 roll of film" mode (Button 17) for continuous use with a single roll of film or select "2 rolls of film" mode (Button 18) for use with two rolls of film). (See 'Electronic control box functions'). The table must be in the correct starting position.

McHale 991 High Speed Round Bale Wrapper

Follow the procedure below:

1. Ensure the bale lift arm is lowered to the ground.
2. Drive the tractor up beside the bale to be wrapped. It will take practice to line up the bale correctly with the wrapper. Ensure the lift arm goes under the bale.
3. Switch to load the bale.
4. The wrapper should now go through a sequence either worked manually, or automatically.
 - (a) The bale lift arm lifts the bale onto the wrapping table (manual). The auto load cycle can be activated using the control box.
 - (b) The bale lift arm is lowered to the ground again.
 - (c) The table starts rotating and plastic film is applied to the bale.
 - (d) After a few revolutions the plastic is released out of the cut & hold.
 - (e) The table slows down two revolutions before the required number of revolutions is reached.
 - (f) The table stops rotating when the required number of rotations is reached. It is now lined up for tipping off.
 - (g) The table is tipped automatically if the “Continuous cycle” is switched on. Otherwise the “tip” button must be pressed.
 - (h) The bale damper raises up and the table tips.
 - (i) The cut and hold closes, holding and cutting the plastic film.
 - (j) The table and bale damper lower down, the bale is lowered to the ground and the pull arm rises again.
 - (k) The table resets to loading position as it is being lowered.
5. The wrapper is now ready to receive another bale.
6. When changing the plastic film rolls, always shut down the tractor and electronics. Always remove the ignition key from the tractor.



WARNING: Ensure the area is clear before operating the wrapper

Always ensure there is no person or wrapped bales in the way of the wrapper before operating it again.



WARNING: Turn off power before changing plastic film rolls

Always turn off the power source and the electronic control box, before changing the plastic film roll.

9

Road traffic safety & operation

9.1 Before travelling on any public roadway



WARNING: Complete a full inspection before travelling on the road

Ensure that a full inspection is completed every time before attempting to go on to a public roadway, always think and practice safety!



NOTE: Check lighting system before travelling on the road

Before travelling on a public road, the operator must ensure that the complete (tractor and machine) lighting system is in a fully functioning condition.

The following must be checked, as a minimum requirement, before moving the machine on a public road.

1. Bale lift arm must be in the fully raised position. The transport lock must be in the locked position while travelling on the road.
2. The hydraulic supply must be turned off and protected from accidental activation by disconnecting the hydraulic feed line. Support all loose lines in a safe manner.
3. Ensure the lights are connected and working correctly. The bale damper must be raised to comply with lighting regulations.
4. Ensure the electronic control box is switched off.
5. If plastic film is to be transported on the machine it must only be done so on the holders provided and secured, if necessary.
6. Ensure that the knife guard is closed on the cut and hold, to prevent injury.
7. Ensure that the tyres are set to the correct pressure as per safety decal and according to the specifications. (See 'General specifications')
8. Attention must be paid to the maximum travel speed-limit of 40 km/h.
9. Ensure that all the national road traffic regulations relating to the country are fulfilled i.e. the use of safety chains may be mandatory in certain countries.



Transport lock, unlocked



Transport lock in the locked position

10

Field operation & wrapper adjustments

From time to time it may become necessary to carry out adjustments to the machine, whether to improve machine performance or allow for general wear and tear. Such adjustments are part of the machine design. The following chapter gives details of how to go through the various adjustments. Some of these are field adjustments while others will be performed during machine maintenance or initial set-up. All of these adjustments should be checked thoroughly before the machine goes to work for the first time.

10.1 Drawbar height

The height of the drawbar may be adjusted to allow for the use of different tractors. The wrapper should be parallel to the ground when working. To change the height go through the following procedure:

1. Ensure the machine is securely chocked and supported
2. Remove the 6 x M16 nyloc nuts and the 6 x M16 bolts attaching the drawbar
3. Move the drawbar to the new location
4. Insert the 6 x M16 bolts and tighten the nyloc nuts
5. Remove the support and chocks

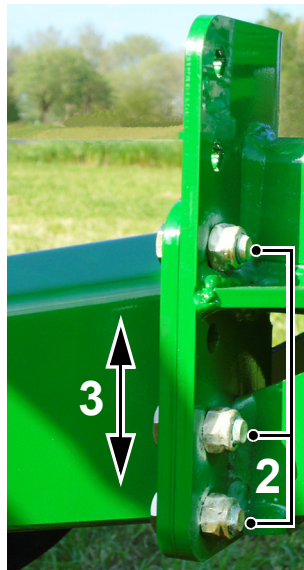

Drawbar height adjustment

10.2 Dispenser height

The plastic film needs to be applied around the centre of the bale, to ensure optimum coverage. The dispenser may need to be adjusted up or down, as necessary.

1. The dispenser post height is adjustable using the ratchet link
2. When wrapping a 1,200 to 1,250 mm diameter bale with two rolls of film, the dispenser post must be set in its lowest position.
3. When wrapping a 1,200 to 1,250 mm diameter bale with one roll of film the dispenser post must be set in its highest position and the one roll of film must be placed in the lower dispenser. (See 'Loading plastic film')



Wrapping with 2 rolls of film

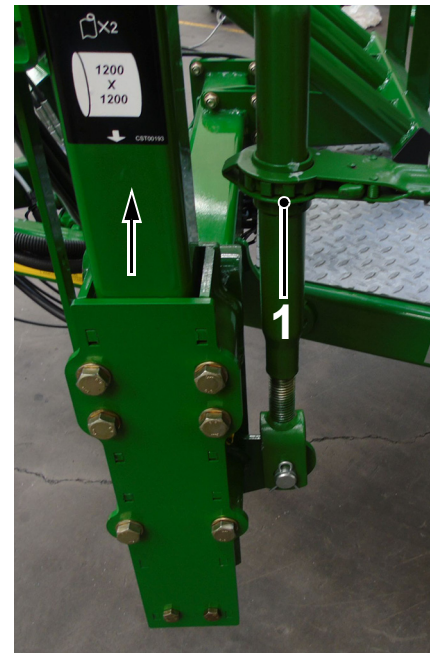

Wrapping with 1 roll of film

10.3 Table rollers/belts

The wrapper normally leaves the factory with rollers set to the correct width for a 1,250 mm diameter bale. Sometimes it may be necessary to narrow the rollers for a smaller diameter bale or widen them for a larger diameter bale. The belts should support the full weight of the bale and should sit tightly between the rollers.

1. Loosen the 4 x M14 nyloc nuts and bolts holding bearings on idle roller.
2. Move roller as desired ensuring both ends are moved the same amount.
3. Tighten the 4 x M14 nyloc nuts and bolts.

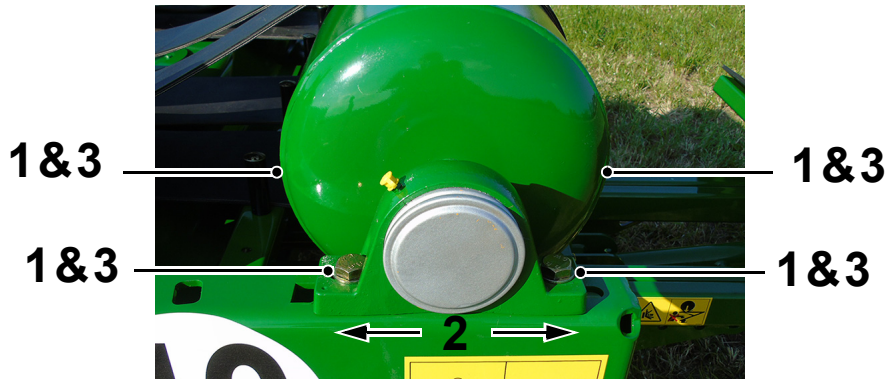

10.4 Adjusting table magnets

If the table does not stop or index to the loading position, it is possible to modify the position of the relevant magnets to rectify this.



WARNING: When performing maintenance, ensure the safety bar is fitted securely while the table is elevated!

1. Start the tractor/power unit and elevate the table fully, by operating the tip up function.
2. Remove the R-pin and swing the safety bar into position. Secure it onto the chassis using the R-pin.
3. Stop the tractor/power unit and ensure that it cannot be restarted, while working on the machine.
4. Secure the safety bar back into its storage position, when maintenance work is complete.
5. Lower the table by operating the tip down function.

10.4.1 Table stop position magnet

If the table does not stop in the correct position in line with the chassis, it is possible to move the magnet that controls the stop position. However, it must be checked first that the machine is operating at the correct speed, has a bale on the table and the plastic film is attached, as all of these factors will have a bearing on where the machine stops. (See 'Troubleshooting')

The magnet may be adjusted as follows:

1. Tip up the table and fit the safety bar
2. Identify the magnet to be changed. There are two sets of magnets near the outside of the table. The magnets that require adjusting are positioned furthest away from the cut & hold.
3. Loosen the M6 bolt and nyloc nut holding the magnets in position
4. If the table does not turn far enough, push the magnets in the direction shown
5. If the table turns too far, push the magnets in the direction shown
6. Tighten the M6 bolt and nyloc nut (Do not overtighten as the magnets may crack or shatter)

McHale 991 High Speed Round Bale Wrapper

7. Remove the table safety bar and lower the table back down
8. Test the machine in automatic mode to see if it is stopping correctly, if it is not re-adjust

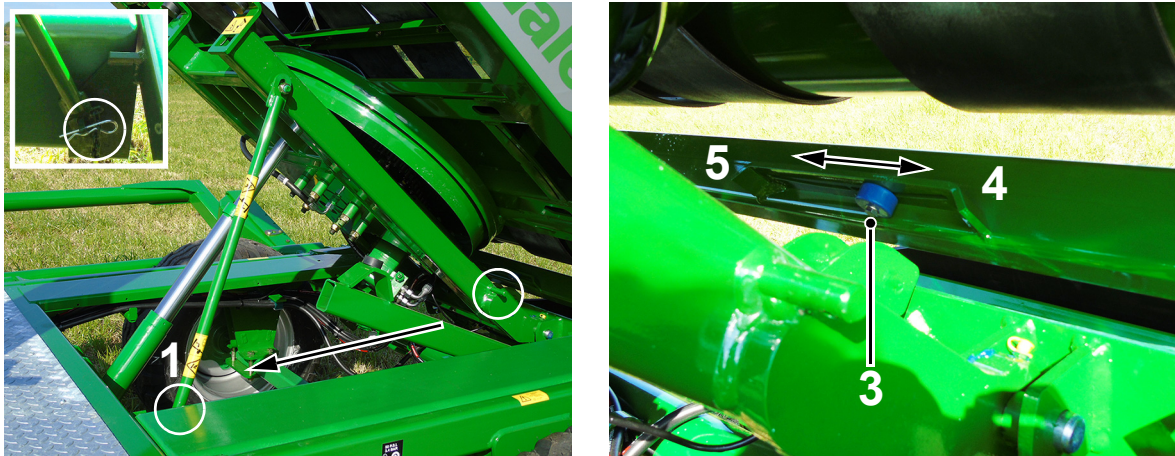

10.4.2 Table load position magnet

If the table does not start in the correct position, in line with the chassis and with the cut & hold to the left, it is possible to move the magnet that controls the start position. Firstly, however, this must be checked with the machine operating at the correct speed, having a bale on the table with plastic film attached, as all of these factors will have a bearing on where the machine stops. (See 'Troubleshooting')

The magnet may be adjusted as follows:

1. Tip up the table and fit the safety bar
2. Identify the magnet to be changed. There are two set of magnets near the outside of the table. The magnets that require adjusting are positioned nearest the cut & hold.
3. Loosen the M6 bolt and nyloc nut holding the magnets in position and move as follows
4. If the table does not turn far enough, push the magnets in the direction shown
5. If the table is turning too far, push the magnets in the direction shown
6. Tighten the M6 bolt and nyloc nut (Do not overtighten as the magnets may crack or shatter)
7. Remove the table safety bar and lower the table back down
8. Test the machine in automatic mode to see if it is stopping correctly, if it is not re-adjust

McHale 991 High Speed Round Bale Wrapper

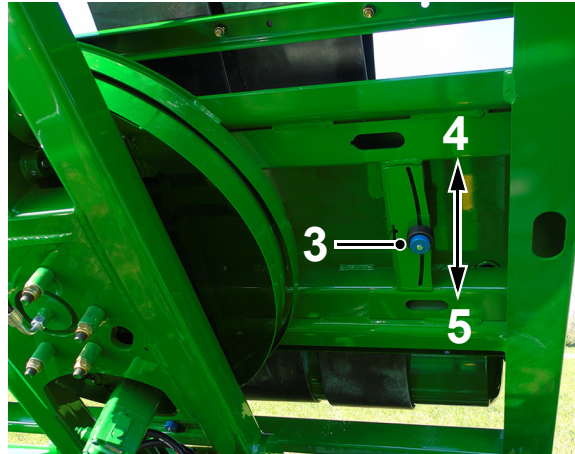
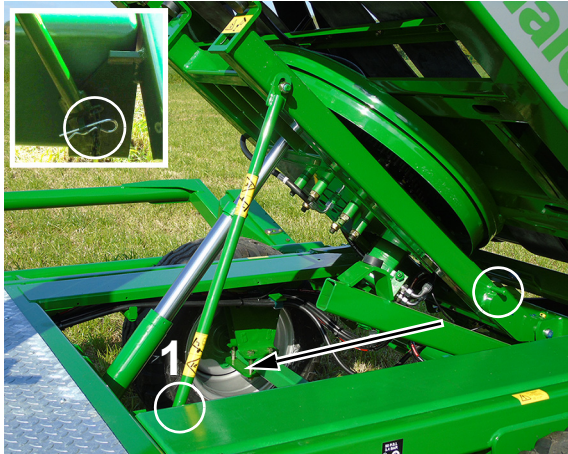

10.4.3 Table down magnet

The table down magnet does not normally require adjustment. However, as it is used to signal the table to start indexing to the loading position, it may need to be re-set.

1. Tip up the table and fit the safety bar
2. Loosen the M6 nut on the magnet
3. Move the magnet upwards to sense when the table is nearer the chassis, i.e. the table lowers more before indexing
4. Move the magnet downwards to sense when the table is further away from the chassis, i.e. the table lowers less before indexing. Do not push down too far, as the table may hit the bale damper while indexing.
5. Tighten the M6 nut.
6. Remove the table safety bar and lower the table back down. Test to ensure that the machine is operating correctly and re-adjust, if necessary.

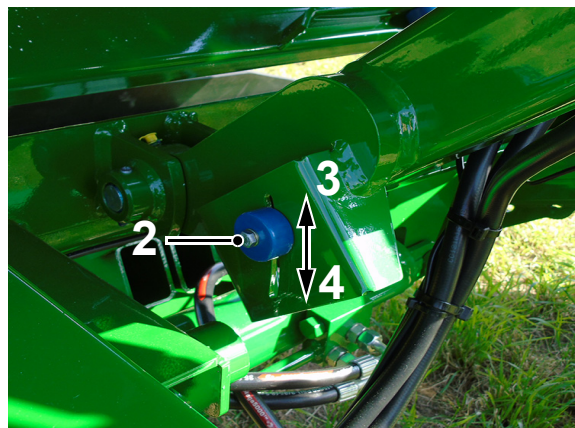
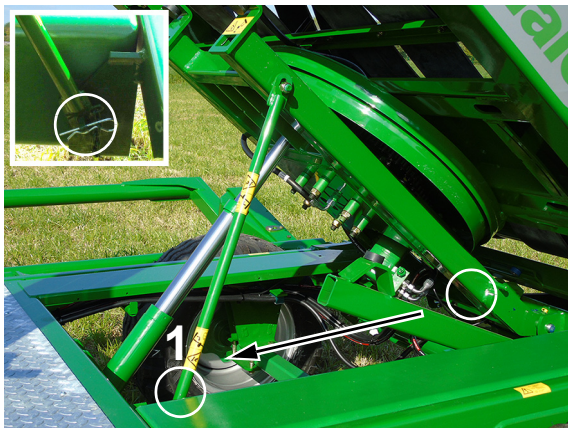

10.5 Bale damper lift height

The transition between the bale being tipped off the table and onto the bale mat must be gentle. To achieve this, the end of the operating cylinder can be adjusted. Do not carry out this procedure with a bale on the wrapper!

1. Raise up the bale damper and support it securely. Do not rely on hydraulic pressure.
2. Loosen the locking nut and screw it away from the cylinder rod.
3. Turn the cylinder rod to lengthen or shorten the rod eye, as desired.
4. Tighten the locking nut.
5. Remove the support and lower the bale damper. Test the machine and re-adjust, if necessary.



10.6 Bale damper drop speed

The drop speed of the bale damper may be adjusted to allow for the great variation in bale weights. The bale should not be allowed to drop too quickly so as not to cause any machine damage.

1. Locate the restrictor valve on the right hand side of the chassis
2. Turn it anti-clockwise to speed up drop speed
3. Turn it clockwise to slow down drop speed
4. Test the machine and re-adjust, if necessary



10.7 Table drive roller shearbolt replacement

There is a shearbolt fitted to the driven table roller sprocket to prevent overloading of the table rollers.

If it is broken, it may be replaced as follows:

1. Remove the two handwheels and chainguard over the table roller drive chain
2. Remove the broken parts of shearbolt and discard them safely
3. Line up the hole in the sprocket with hole in the drive flange
4. Fit the replacement M8 x 35 shearbolt (CFA00055) and nut (CFA00132). Do not fit stronger bolts as replacements!
5. Replace the chain guard and the two handwheels

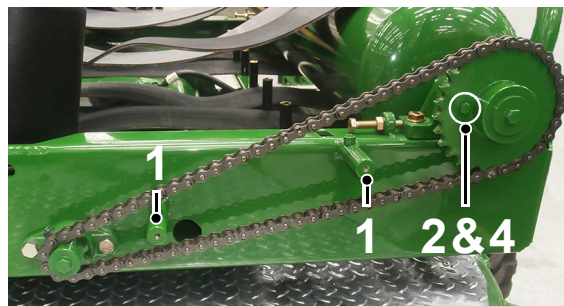

10.8 Gearbox cross shaft roll pin replacement

As a secondary overload protection device, the gearbox cross shaft is protected by roll pins which will shear, when overloaded. This mainly applies to older machines as newer machines have an additional keyway which prevents this from happening.

If this occurs, they may be replaced as follows:

1. Remove the 6 x setscrews holding on the cover of the gearbox. Remove the cover and gasket.
2. Remove all broken parts of the roll pins
3. Ensure the hole in the table cross shaft and the hole in gearbox cross shaft line up correctly
4. Fit new roll pins (CFA00006 & CFA00009). Do not fit anything other than these!
5. Replace the gearbox cover ensuring the gasket is serviceable. If not, replace the gasket with a new part (CSE00006).
6. Replace the 6 x setscrews

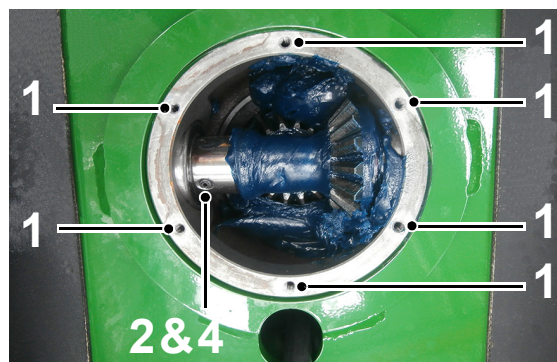

Gearbox cross shaft pin replacement

10.9 Cut & hold accumulator pressure

The cut & hold is held open by a hydraulic accumulator which is primed as the cut & hold is closed. If for whatever reason the pressure drops, it will prime again the next time the cut and hold is closed. If the **991 High Speed** is used on a tractor with high oil pressure and is then changed to a tractor with a lower oil pressure then the accumulator may need to be discharged if the cut and hold is not closing fully.



WARNING: Care must be taken when carrying out this procedure

It is very important that care is taken in carrying out the following procedure to protect both the operator and any personnel that may be nearby! If you are unsure of how to carry out this procedure entrust the job to your **McHale** dealer.

10.9.1 To decrease accumulator pressure

1. Place a spanner on the banjo bolt, but do not turn the bolt.
2. Wrap the spanner and bolt with a cloth to stop the oil spray then turn the bolt a half turn. This should allow the oil to leak out and reduce the pressure. If no oil leaks then turn the spanner a quarter turn at a time until it leaks off the oil pressure.
3. Tighten the banjo bolt once the oil pressure is reduced.
4. Once the cut and hold is operated again the accumulator will be charged automatically to the correct pressure.

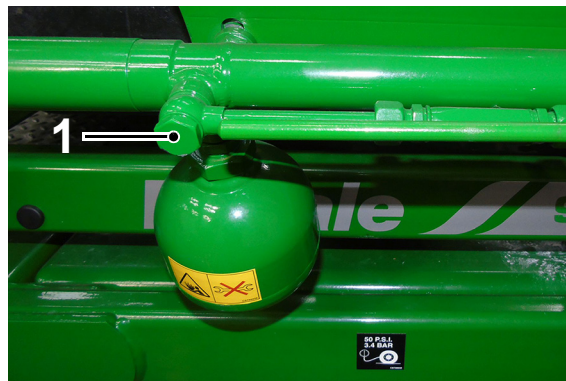

10.10 Chain adjustments

It is important for the efficient operation of the machine that all drive chains are kept correctly tensioned. The following is a general guide to chain adjustment.

The sag is measured at the midpoint of the chain between the sprockets. Always ensure one side of the chain is tight so that the correct reading is obtained. Even though some drives differ in detail the basic adjustments stay the same.

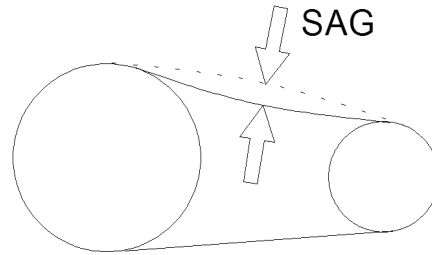

WARNING: When performing maintenance, ensure the safety bar is fitted securely while the table is elevated!

1. Start the tractor/power unit and elevate the table fully, by operating the tip up function.
2. Remove the R-pin and swing the safety bar into position. Secure it onto the chassis using the R-pin.
3. Stop the tractor/power unit and ensure that it cannot be restarted, while working on the machine.
4. Secure the safety bar back into its storage position, when maintenance work is complete.
5. Lower the table by operating the tip down function.

10.10.1 Table drive chain

After a period of time, it may become necessary to readjust the drive chain.

To adjust go through the following procedure:

1. Tip up the wrapper table and fit the safety bar securely
2. Stop the tractor/power unit and ensure that it cannot be restarted, while working on the machine.
3. Loosen the 4 x M16 bolts holding on the motor plate
4. Turn the M16 nyloc nut to adjust the chain. There should be 10-13 mm of sag in the chain.
5. Tighten the 4 x M16 bolts holding on the motor plate
6. Remove the table safety lock and lower the table down

McHale 991 High Speed Round Bale Wrapper

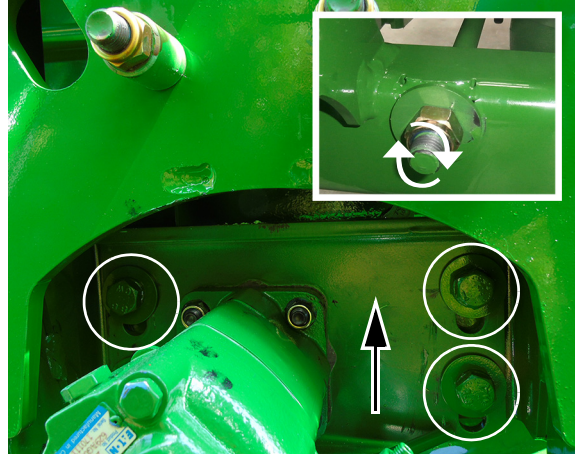
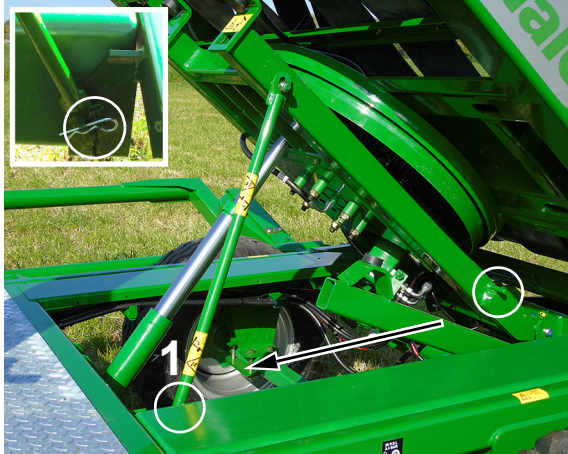

10.10.2 Table roller drive chain

After a period of time, it may become necessary to readjust the table roller drive chain.

To adjust go through the following procedure:

1. Remove the chain guard by undoing the two handwheels
2. Loosen the 4 x M16 nuts and bolts holding on the bearings
3. Adjust the roller using the 2 x M10 adjuster setscrews on each end of the roller. Always ensure both ends have been moved by the same amount.
4. Tighten the 4 x M16 nuts and bolts on the bearings
5. Replace the chain guard with the two handwheels

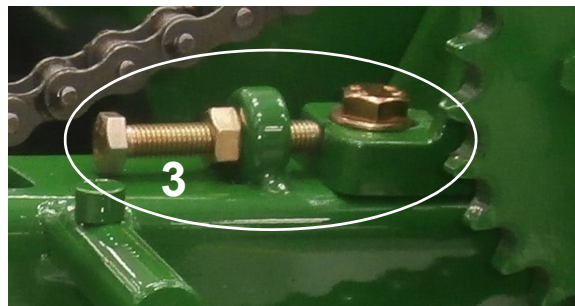
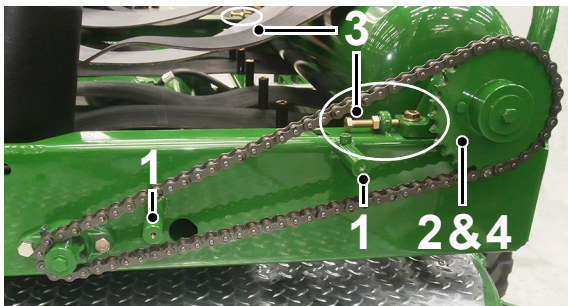

11

Machine maintenance

To maintain the machine in good working order it is necessary to carry out preventative maintenance regularly. The following section gives details of how this may be carried out and how often it will be required.

Replace any electrical or hydraulic devices immediately, at the first sign of malfunction or failure, as these components affect the functionality, sequencing and thus safety of operation. Never use a machine where a malfunction exists! Contact your **McHale** dealer to achieve a solution. Always think 'Safety First'!



WARNING: Wear proper safety equipment & follow all instructions

Ensure to wear proper safety equipment at all times when working with the machine, such as gloves, eye protection, etc. and follow all safety decals and instructions.

11.1 Maintenance intervals

The following intervals should be adhered to, in order to ensure a long and efficient life for the machine and maximum safety of personnel. They assume constant working during the wrapping season.

First 5 working hours

1. Check all nuts and bolts for tightness and tighten, if necessary
- 2.* Grease bale lift arm hydraulic cylinder ends

McHale 991 High Speed Round Bale Wrapper

Every day

1. Grease bale lift arm hinges
- 2.* Grease bale lift arm hydraulic cylinder ends
3. Grease sub chassis pivots
4. Grease table tip hydraulic cylinder ends
5. Grease bale damper hinge pivots
6. Grease bale damper hydraulic cylinder ends
7. Grease side tip bale damper hinges (option)
8. Check wheel nuts and tyre pressure
9. Check all guards and safety devices
10. Check for any oil leaks and damaged pipes
11. Check road traffic equipment (lighting and transport lock bar)



2*

WARNING: Pay particular attention to the outer ram pin on the bale lift arm

The outer ram pin connecting the ram piston to the bale lift arm is under extremely heavy load and must be greased daily! If the pin is becoming difficult to grease or if there is any noticeable wear (max 2 mm play), then the pin must be replaced immediately. When the pin is being replaced, ensure that the transport lock is in the locked position on the bale lift arm. The bale lift arm should be well supported with lifting gear or slings, to prevent it from moving or falling.

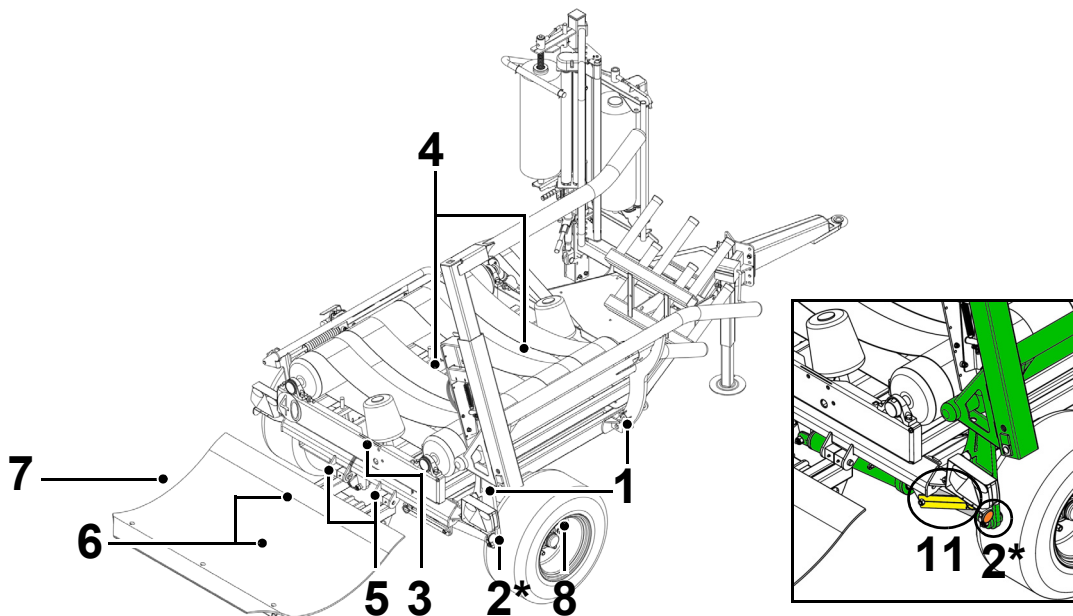

McHale 991 High Speed Round Bale Wrapper

Every week

1. Grease table roller bearings
2. Grease cross shaft bearing
3. Grease dispenser top coil roller shafts
4. Grease cut and hold plunger
5. Grease bale damper side-tip latch

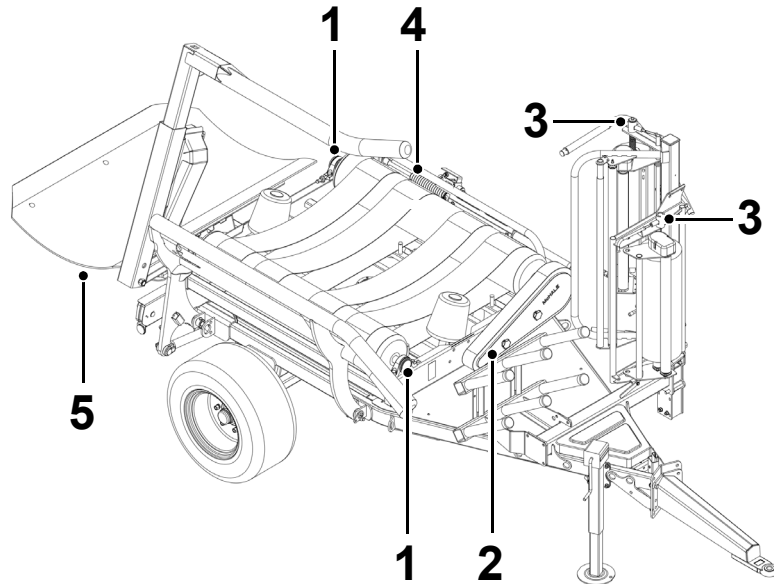

Every month

1. Grease parking jack

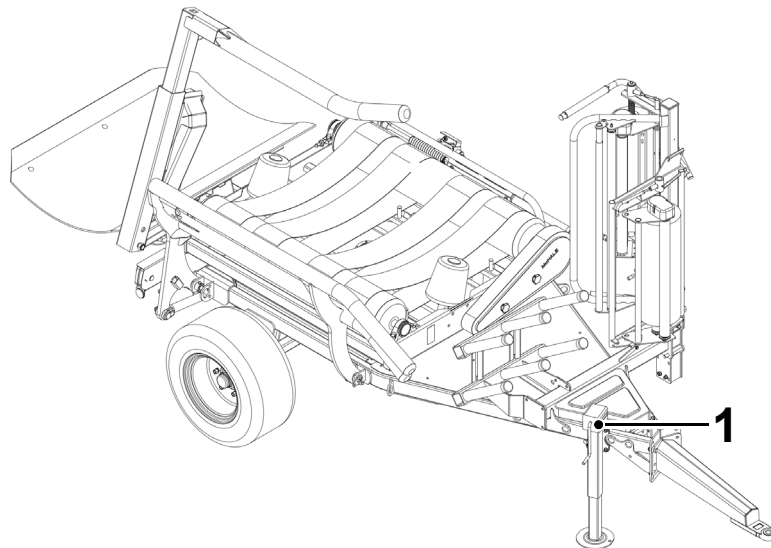

McHale 991 High Speed Round Bale Wrapper

Every year

1. Clean and lubricate dispenser gears
2. Check table gearbox for grease
3. Grease shearbolt to sprocket flange on table drive roller

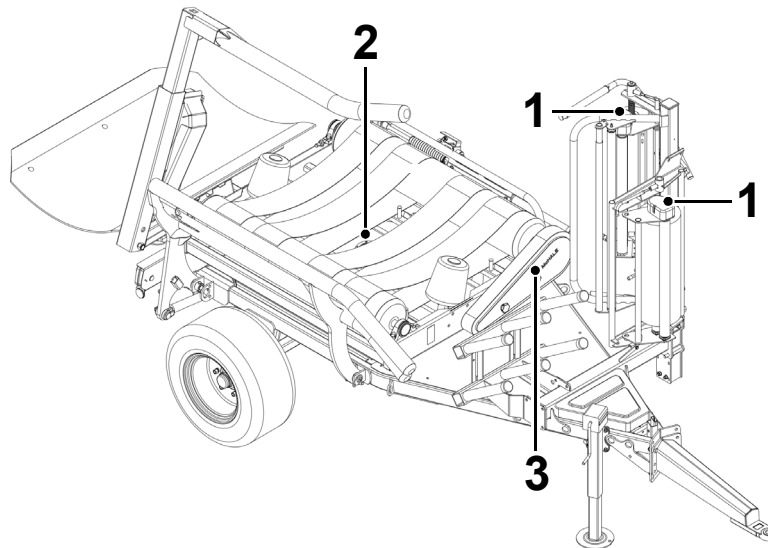

CAUTION: Hydraulic hoses to be replaced every 5 years

All hydraulic hoses must be replaced every 5 years. If any hoses are removed or replaced ensure they are marked and re-installed to the correct position during re-assembly.

It may become necessary from time to time to clean the dispenser rollers as they pick up the 'tack' from plastic film. Clean off with kerosene.

At the end of the season the machine should be washed and cleaned.

Carefully clean all machine sections, inside and out. Dirt and foreign objects are likely to draw moisture and cause rusting of steel components. **McHale** recommend that the machine be blown down with an air line, as opposed to a pressure washer, due to the dangers involved with pressure washing and to protect the overall paint work on the machine. If, despite our advice, a pressure washer is used then take extreme caution and operate from ground level only. Do not point pressurized water at or near electrical components, pivots points, valves or bearings. Never climb onto any part of the machine, while pressure washing, due to the fact that all metal surfaces become extremely wet and slippery and always ensure that the tractor has been shut down, with the ignition key removed.

Any damaged paintwork should be touched up. Any maintenance or repairs should be carried out at this stage. The electronic control box is not waterproof, so it must always be stored in a dry environment. (See 'Storage'). All exposed hydraulic cylinder rods should be greased.



WARNING: Inspections in the 'Danger Zone' with the machine running, shall only occur with a trained operator at the controls

Entering the 'Danger Zone' while the machine is running is not recommended. If it is to be carried out, a fully trained operator shall be at the controls. The tractor hand brake shall be applied and the electronic control box shall be in manual mode. The operator shall remain in communication with the inspector throughout. If communication is lost with the inspector, or they move within 1.1 m of moving parts or parts that have the potential to move, all tractor power shall be turned off immediately.



ENVIRONMENT: Health and safety rules for the environment

It is vitally important to observe health and safety rules in order to avoid unnecessary environmental damage or danger to anybody near the machine. This especially applies to the responsible disposal of oil. Never spill pollutants (oil, grease, filters, etc.) on the ground, never pour them down the drain and never discard them where they can pollute the environment. Always take waste materials to a recycling centre.

11.2 Tightening torque values

It is important that the correct torques for fasteners are adhered to. Below are tables of recommended torques for these. These are to be used unless torques are otherwise specified. These values are for general use only. Check tightness of all fasteners periodically. Torque values are in Nm (Newton metres).

Nuts and bolts		Black, Phosphated or Galvanized		
Grade marking		8.8	10.9	12.9
	Dimensions	Metric standard thread		
Hex. bolts	M4	2.7	3.8	4.6
DIN 931	M5	5.5	8	9.5
DIN 933	M6	10	14	16
	M8	23	33	40
Socket head	M10	45	63	75
Cap screws	M12	78	110	130
DIN 912	M14	122	175	210
	M16	195	270	325
Hex. nuts	M18	260	370	440
DIN 934	M20	370	525	630
	M22	510	720	870
	M24	640	900	1,080
	M27	980	1,400	1,650
	M30	1,260	1,800	2,160
	Dimensions	Metric fine thread		
Hex. bolts	M8 x 1	25	35	42
DIN 960	M10 x 1.25	48	67	80
DIN 961	M12 x 1.25	88	125	150
	M12 x 1.5	82	113	140
Hex. nuts	M14 x 1.5	135	190	225
DIN 934	M16 x 1.5	210	290	345
	M18 x 1.5	300	415	505
	M20 x 1.5	415	585	700
	M22 x 1.5	560	785	945
	M24 x 2	720	1,000	1,200
	M27 x 2	1,050	1,500	1,800
	M30 x 2	1,450	2,050	2,500
NOTE:	For nuts and bolts from different materials and/or surface finishes a torque value must be used that is lower than the value stated above.			

12

Storage

12.1 End of season

- Carefully clean all machine sections, inside and out. Dirt and foreign objects are likely to draw moisture and cause rusting of steel components. **McHale** recommend that the machine be blown down with an air line, as opposed to a pressure washer, due to the dangers involved with pressure washing and to protect the overall paint work on the machine. If, despite our advice, a pressure washer is used then take extreme caution and operate from ground level only. Do not point pressurized water at or near electrical components, pivots points, valves or bearings. Never climb onto any part of the machine, while pressure washing, due to the fact that all metal surfaces become extremely wet and slippery and always ensure that the tractor has been shut down, with the ignition key removed.
- Remove the control box from the tractor and store in a dry, safe environment.
- Lubricate all pivot points and apply a thin layer of grease to all adjustment bolt threads and exposed ram rods.
- Any components from which paint has become worn should be touched up or coated with grease to prevent rusting.
- Remove all dirt from all chains and blow dry using compressed air.

12.2 Start of season

- Fully review this operators instruction manual.
- Lubricate all pivot points.
- Tighten all bolts, nuts and setscrews. (*See 'Tightening torque values'*)
- Check air pressure of all tyres.
- Connect the control box and inspect it for the correct operation of all functions. (*See 'Electronic control box functions'*)
- Inspect and modify, if necessary, all machine adjustments. (*See 'Field operation & wrapper adjustments'*)
- Check film wrapping adjustments and replace cut and hold knife. Ensure to wear protective clothing whenever working in this area!
- Inspect aluminium dispenser rollers for a build up of tack/glue, clean off using kerosene or diesel oil and wipe rollers dry.

13

Troubleshooting

13.1 Troubleshooting overview

This section has been compiled by **McHale** service personnel in conjunction with **McHale** importers and dealers.

It outlines some common problems which can occur and acts as a quick reference section or check list to resolve the problem. It is important to note that it outlines the common problems and to this effect it is not exhaustive.

Should you experience additional problems which you need help with; please do not hesitate to contact your **McHale** dealer.

13.1.1 Lift arm and table

Symptom	Reason	Solution
Lift arm not operating	Faulty power supply/ electrical connections	Check and correct
Table rotates but bale not indexing	Table drive roller shearbolt broken	Replace shearbolt
Table stopping in the wrong position	Magnet settings	Reset magnets
	Not starting in the correct position	Start with cut & hold at the rear of the machine
	Slow down setting in the control box	Adjust
	Slow speed valve not working	Check electrical connections
	Dirt in slow speed cartridge	Clean cartridge
Table moving in tip position	Drive chain loose	Tighten chain
Table slow to tip down	Back pressure too high	Ensure free flow return is fitted
	Faulty quick release couplings	Replace couplings

McHale 991 High Speed Round Bale Wrapper

Symptom	Reason	Solution
Machine tips bale but does not reset to load	Tip sensor faulty	Locate and replace
	Magnet broken	Locate and replace

13.1.2 Plastic film

Symptom	Reason	Solution
Plastic film splitting as bale leaves table	Bale sticking to roller as it is leaving the table	Shake chalk under belt to reduce friction
	Bale damper ram adjusted too high	Adjust damper cylinder
Plastic not stretching	Building up of tack/glue on dispenser rollers	Clean off with kerosene
	Torsion spring weak on dispenser	Replace spring
Plastic getting caught around the cut & hold	Table down magnet set too high	Reset table down magnet

13.1.3 Damper

Symptom	Reason	Solution
Damper slow or fails to come down	Restrictor tap set too tight	Adjust restrictor
Damper rising during wrapping cycle	High hydraulic back pressure	Fit free flow return
	Faulty quick release coupling	Replace quick release coupling

13.1.4 Cut & hold

Symptom	Reason	Solution
Cut & hold not catching plastic film	Positioned incorrectly	Check position
	Table not stopping in the correct tip off position	Check and adjust magnets if necessary
Cut & hold not opening	Pressure low on accumulator	Prime accumulator
Cut & hold not closing	Pressure high on accumulator	Release pressure from accumulator

McHale 991 High Speed Round Bale Wrapper

Symptom	Reason	Solution
Cut & hold leaks back slowly	Seals weak in the gearbox	Replace seals
	Loose hydraulic fitting on gearbox	Tighten hydraulic fitting
Cut & hold and tip-up cycles very slow	Tractor pressure too low	Ensure tractor has 150 bar pressure
	Faulty pressure switch (electronic machines)	Replace pressure switch
	Relief valve set too low	Set to 150 bar pressure
Cut & hold not cutting film	Damaged blade or knife guard still closed	Replace blade and/or open knife guard

13.1.5 Control box

Symptom	Reason	Solution
Control box not counting	Sensor damaged	Locate and replace
	Magnet broken	Locate and replace
	Sensor - magnet clearance	Adjust sensor approx. 10-15 mm from magnet
	Faulty control box	Replace control box
"LOW BATT" appears on the control box	Supply voltage too low	Check battery and charging system
Only half the number of actual rotations is displayed on the control box	One set of magnets missing	Replace the missing set of magnets
Control box will not switch to "auto" setting	Loom not connected to the box	Connect loom

13.1.6 Hydraulics

Symptom	Reason	Solution
Hydraulics under pressure when the wrapper is idle	Valve set to closed centre on open centre system	Change the setting
Hydraulic system vibrating	Incorrect valve setting for the tractor being used	Set the valve to suit the tractor hydraulic system being used

13.1.7 Remote control

Symptom	Reason	Solution
Remote control receiver not accepting a signal	Not connected properly	Check on the rear of the control box
	Batteries exhausted on a handpiece	Replace the batteries
	Not pressing the Start button for long enough	Press the button for 2 to 3 seconds
	Sunlight shining direct into the receiver (infrared type receivers only)	Turn away or shade
	Operating through tinted glass (infrared type receivers only)	Operate where glass cannot come in the way

13.1.8 Control valve

Symptom	Reason	Solution
Dump valve on control valve leaking (electronic machines)	Back pressure too high	Ensure free flow return is fitted
	Return hose not connected	Connect hose

14

Certification & Warranty

14.1 Declaration of Conformity

The Declaration of Conformity is provided by **McHale**. It certifies the new machine under all the relevant provisions of the EC machinery directive and the national laws and regulations adopting this directive.

The declaration gives a description of the machine and its function, along with the model and serial number details. (See '*Declaration of Conformity*')

By any alteration of the machine, the Declaration of Conformity, as well as the CE sign on the machine, loses its validity.

14.2 PDI form

The PDI (pre-delivery inspection) form is filled out on the commissioning of every new machine, by the **McHale** dealer. The following checks are completed and signed off:

- All parts and accessories are provided to the customer, with the machine
- Machine is reassembled correctly
- Tyre pressure is correct
- Hydraulics, electrics and lighting are working
- New owner has been instructed on how to operate & maintain the machine

The PDI is included in this operator manual. (See '*Pre-Delivery Inspection Form*')

14.3 Change of ownership pre-checks

The PDI (pre-delivery inspection) form that is filled out on the commissioning of every new machine, should also be used during the transfer of ownership of a **McHale** machine. The same check list must be completed and any areas requiring attention addressed before the re-sale of the machine should occur. Pay particular attention to all safety related areas. Take time to familiarise the new owner with machine operation, maintenance and all its safety features.

14.4 Limited Warranty

Limited Warranty conditions are supplied with each **McHale** product. They cover the terms & conditions associated with abnormal failure under normal working conditions. (See '*McHale Limited Warranty*')

Declaration of Conformity



DECLARATION OF CONFORMITY

We hereby certify that the machinery stipulated below complies with all the relevant provisions of the EC Machinery Directive 2006/42/EC and the national laws and regulations adopting this directive. Modifications to the machine, without prior approval from the undersigned, will render this declaration null and void.

Machine description and function: Round bale wrapper for wrapping bales of agricultural fodder with agricultural bale wrap film.

Model: (991) _____ **Serial Number:** _____

Name of manufacturer: McHale Engineering
Address: Ballinrobe, Co. Mayo, Ireland, F31 K138

Is also in conformity with the provisions of the following other EU directives:
2014/30/EU - Electromagnetic compatibility (EMC)

Technical file compiled by: James Heaney
c/o McHale Engineering
Ballinrobe, Co. Mayo, Ireland, F31 K138

Harmonised standards applied:
EN ISO 12100 Safety of machinery - General principles for design - Risk assessment and risk reduction
EN ISO 4254 - 1 Agricultural machinery - Safety - Part 1: General requirements
EN ISO 4254 - 14 Agricultural machinery - Safety - Part 14: Bale wrappers

Signed: 
Date: **Place:** Ballinrobe, Co. Mayo, Ireland, F31 K138
Name: James Heaney
Position: Design Office Manager

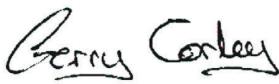
Signed: 
Date: **Place:** Ballinrobe, Co. Mayo, Ireland, F31 K138
Name: Gerry Corley
Position: Quality Manager



Pre-Delivery Inspection Form



PRE-DELIVERY INSPECTION (PDI)

Dealer:.....	Model: 991/995 trailed wrapper
Full address:.....	Serial No:.....
.....	Date Delivered:.....
Fitter:.....	Date Inspected:.....
Customer:	
Full Address:.....	Tel:.....
.....	Mobile:.....
.....	E-mail:.....

ENSURE THAT THE TRACTOR IS OF THE CORRECT SPECIFICATION FOR THIS MACHINE.
REFER TO THE OPERATOR INSTRUCTOR MANUAL BEFORE MAKING ANY ADJUSTMENTS!

This machine must be registered on www.mchale.net by the Dealer in order to qualify for Warranty!

1. Check that all accessories are with the Owner/Operator. Check Operators Instruction Manual and Parts Lists.		10. Where the remote control option is supplied with machine ensure it is fitted correctly.	
2. Ensure machine is re-assembled correctly. (Refer to all assembly instructions supplied)		11. Check all manual functions on the control unit. Run machine through automatic cycle on the control unit.	
3. Ensure that the wheels are correctly fitted (i.e. valve to the outside). Torque wheel nuts correctly.		12. Check for smooth operation of the lift-arm, table, rollers and all moving parts.	
4. Check for correct tyre type, tread and pressure. (Tyre inflation pressure is 3.4 bar (50 psi))		13. Check that all electrics and lights function correctly.	
5. Ensure drawbar is fitted correctly before coupling machine to tractor. Torque all bolts.		14. Check dispenser(s) are running smoothly & free from damage or grit.	
6. When hitched to tractor check that the machine is parallel with the ground. Adjust drawbar if necessary. Attach 7-pin plug for lighting system.		15. The operator must be fully aware of all hazards, controls (electric & hydraulic), all functions & safety devices of both the machine and the tractor.	
7. Connect hydraulic hosing to tractor and ensure proper hydraulic setup. Note: Ensure free-flow return to tank.		16. Ensure that the owner/operator reads the operator instruction manual and understands fully all safety & operating aspects of the machine, as described.	
8. On electronic machines ensure control-unit power is 12 V direct from battery or a malfunction may occur.		17. Instruct operator on machine maintenance i.e. check chain tensions, adjustments, tyre pressure & wheel nuts, also areas to be greased daily along with all other routine functions.	
9. On electronic machines ensure that the control-unit is on the correct program to suit the machine and that it is starting and finishing in the correct position.			

I am satisfied that the above checks have been carried out, and that the machine is complete with all accessories and manuals.

Signed:.....	(Dealer)	Date:.....
Signed:.....	(Owner)	Date:.....

A signed copy of this form is to be retained by both the Dealer and the Customer!

McHale Limited Warranty

McHale Engineering, Ballinrobe, Co. Mayo, Ireland (hereinafter called 'the company') warrants to the original retail purchaser that new products sold and registered with the company, shall be, at the time of delivery, free from defects in material and workmanship, and that such equipment is covered under Limited Warranty providing the machine is used and serviced in accordance with the recommendations in the operator's manual.

This Limited Warranty covers the equipment for 10,000 bales, or a period of one year starting from the date the equipment is commissioned, whichever comes first.

The online submission of the pre-delivery inspection (PDI) form by the dealer (importer) is taken as evidence of the delivery of the machine to the original retail purchaser. This is compulsory, and is required to record the machine in the **McHale** warranty system.

These conditions are subject to the following exceptions:

- Parts of the machine which are not of **McHale** manufacture, such as tyres, PTO shafts, slip clutches, hydraulic cylinders, etc. are not covered by this Limited Warranty, but are subject to the warranty of the original manufacturer. Warranty claims applying to these types of parts must be submitted in the same way as if they were parts manufactured by **McHale**. However, compensation will be paid in accordance with the warranty agreement of the manufacturer concerned.
- This Limited Warranty does not apply to failure through normal wear and tear, to damage resulting from negligence or from lack of inspection, from misuse, from lack of maintenance and/or if the machine has been involved in an accident, lent out or used for purposes other than those for which it was intended by the company.
- This Limited Warranty will not apply to any product that has been altered or modified in any way without the express permission of the company, or if parts not approved by **McHale** are used in repair.
- The company take no responsibility for any additional costs, including loss of oil and/or consumables incurred during the failure and repair of a product.
- The company cannot be held responsible for any claims or injuries to the owner or to the third party, nor to any resulting responsibility.
- Also, on no account can the company be held liable for incidental or consequential damages (including loss of anticipated profits) or for any impairment due to failure, a latent defect or a breakdown of a machine.

The customer will be responsible for the following costs:

- Normal maintenance such as greasing, maintenance of oil levels, minor adjustments, etc. as specified in the operator's manual.
- Labour charges other than originally agreed, incurred in the removal and replacement of components.
- Dealer's travel time and travel costs to and from the machine.
- Parts defined as normal wear items such as, but not limited to PTO shafts, chains, tyres, bearings, belts, blades, knives, tines, tine bars, slip clutches, nylon chain runners and slides, etc. that are not covered under the Limited Warranty.

McHale 991 High Speed Round Bale Wrapper

The importer will be responsible for the following costs:

- All warranty labour charges.

The warranty is dependent on the strict observance of the following:

- The machine has been put in service by the **McHale** dealer according to our instructions.
- The online pre-delivery inspection (PDI) form has been correctly completed by the dealer.
- A printed version of the PDI form has been signed and dated by the original retail purchaser. This copy is to be stored by the dealer and made available to **McHale** when requested.
- The warranty claim is submitted using the **McHale** online claims system.
- The warranty claim must be submitted by the original retailing **McHale** dealer only.
- The decision of the company in all cases is final.
- Warranty parts must be held by the dealer for a period of two years from the date the warranty claim is submitted to **McHale**, or until a return request has been issued within the two years.
- When **McHale** issue a return request, parts must have the claim number written clearly on each individual part. These parts must be free from dirt and oil. If a part is returned in an unfit state, the claim will be refused.
- If damaged parts have been returned to the company and warranty is refused, the dealer is allowed a period of one month from the date of receiving our notification to request the return of the damaged parts to the dealer site.

Further conditions - limits of application and responsibility:

- This Limited Warranty cannot be assigned or transferred to anyone without the prior written consent of the company.
- **McHale** dealers have no right or authority to assume any obligation or take any decision on the company's behalf, whether expressly or tacitly.
- Technical assistance given by the company or its agents for repairing or operating equipment does not lead to any responsibility on the company's behalf and cannot under any circumstances bring novation or derogation to the conditions of the present Limited Warranty.
- The company reserves the right to incorporate changes in its machines without prior notice and without obligation to apply these changes to machines previously manufactured.
- The present Limited Warranty excludes any other responsibility, whether legal or conventional, express or implied, and there are no warranties extending beyond those defined herein.